

GREENWORKS

COMMERCIAL

Zero Turn Mower
2508902 (Model No. GZM60R)



Owner's Manual

TOLL-FREE HELPLINE: 1-855-470-4267

www.GreenworksCommercial.com

 Read all safety rules and instructions carefully before operating this tool.

CONTENTS

Product specifications.....	3
General information.....	4
To the new owner.....	4
Using this manual.....	4
Warranty registration.....	4
Model and serial number.....	4
Parts and service.....	4
Safety information.....	5
Operator.....	5
Machine.....	6
Mowing area.....	6
Mowing.....	6
Servicing.....	7
Charging.....	7
Slope operation.....	7
Child safety.....	8
Using a ramp.....	8
Towing.....	8
Battery & charger.....	9
Symbols.....	10
Know your lawn mower.....	12
Control panel.....	13
Left control panel (with operator seated).....	13
Right control panel (with operator seated).....	13
Steering control levers.....	14
Steering alignment screw.....	14
Safety start interlock system.....	14
ROPS (Roll over Protective Structure).....	15
Work light.....	16
Anti-scalp wheels.....	16
Neutral bypass knobs.....	16
Operation.....	18
Starting your mower.....	18
Stopping your mower.....	18
Driving the mower.....	18
Steering control lever adjustment.....	19
Seat adjustment.....	20
Deck cutting height adjustment.....	20
Operating suggestions.....	20
Slope operation.....	22
Slope guide.....	24
Electrical system.....	25
Electrical system safety.....	25
Electrical system information.....	25
Battery and charger.....	25
Battery charging port.....	26
Battery charger.....	26
Charging recommendations.....	27
Disconnecting the Batteries (Lithium Modules).....	27

Reconnecting the Batteries (Lithium Modules).....	27
Digital display.....	28
Know the digital display.....	28
Error code.....	28
Maintenance.....	37
Regular maintenance.....	37
Tires.....	37
Lubrication.....	37
Mower blade maintenance.....	37
Mower blade removal/installation.....	37
Torque values.....	38
Seat belt maintenance.....	38
ROPS maintenance.....	39
ROPS Inspection.....	39
Possible damage to the ROPS.....	39
Cleaning the mower.....	39
Storing the mower.....	39
No season preparation.....	40
Battery maintenance.....	40
Lithium energy module maintenance.....	41
Service.....	41
Environmentally safe battery disposal.....	43
Troubleshooting.....	44
Troubleshooting.....	44
Deck System Resistance Test Procedure.....	45
Limited warranty.....	46

PRODUCT SPECIFICATIONS

Battery type.....	82V lithium-ion
Gross vehicle weight.....	1358 lbs. (616 kg)
Length overall.....	79"
Width overall (with discharge).....	73"
Height overall.....	48"
Height overall (with ROPS).....	69"
Deck width.....	60"
Forward speed.....	0-10 mph
Reverse speed.....	0-3 mph
Charge time.....	10-12 hrs
Cutting height range.....	1"-6"
Height adjustment.....	1"-6"

GENERAL INFORMATION

This manual applies to the following Greenworks Commercial lines:

To the New Owner

The purpose of this manual is to assist owners and operators in maintaining and operating this Greenworks Commercial mower. Please read the entire manual carefully; the information and instructions provided can help you achieve years of dependable machine performance.

It is the owner's responsibility to make certain that the operators and mechanics read and understand this manual and all decals before operating this machine. It is also the owner's responsibility to make certain that the operators and mechanics are qualified and physically able to operate this equipment. All operators and mechanics must become familiar with the safe operation of this equipment, its controls and safety signs.

Never let children or untrained people operate or service this equipment. Please note that local regulations may restrict the age of the operator.

Using This Manual

General operation, adjustment and maintenance guidance is outlined for both the experienced and novice Greenworks Commercial Mower user. Operating conditions vary considerably and cannot all be addressed individually. Through experience, however, operators should have no difficulty developing good operating skills suitable to most conditions.

Directions used in this manual (e.g., "RIGHT" or "LEFT") refer to directions when either seated on the mower or standing facing forward, unless otherwise stated.

Photographs and illustrations used were current at the time of printing, but subsequent production changes may cause your machine to vary slightly in detail. Greenworks Commercial Products reserves the right to redesign and change the machine as deemed necessary, without notification. If a change has been made to your machine which is not reflected in this owner's manual or the parts manual, see your Greenworks Commercial Products dealer for current information and parts.

Warranty Registration

The owner must register the unit by filling out the Warranty Registration Form, provided in the owner's packet, to validate warranty protection. As the new equipment owner, you are expected to see that this is done at the time of delivery. If using the Warranty Registration Form, it MUST be completed and signed by the authorized dealer and original purchaser. Be sure to register the mower plus each attachment that displays a model and serial identification number plate with Greenworks Commercial.

▲ I M P O R T A N T

Any unauthorized modification, alteration, or use of non-approved attachments voids the warranty and releases Greenworks Commercial from any liability arising from subsequent use of this equipment.

Serial Number

The mower serial number is found on the date label. The serial number and model are required on the Warranty Registration Form. They will also ensure that you receive the correct parts when replacement becomes necessary.

Parts and Service

All warranty repair and service must be handled through an authorized Greenworks Commercial Products dealer. Arrangements should be made through your local service center.

SAFETY INFORMATION

GENERAL SAFETY RULES READ ALL INSTRUCTIONS CAREFULLY

W A R N I N G

This symbol indicates important safety instructions. If these instructions are not followed, it could endanger the personal safety and/or property of the operator and others. Read and understand all instructions in this manual before attempting to operate the mower. Failure to comply with these instructions may result in personal injury.

D A N G E R

This mower was built to be operated according to the rules for safe operation that are contained in this manual. As with any type of power equipment, carelessness or error on the part of the operator can result in serious injury. This mower is capable of amputating body parts and throwing objects. Failure to observe the following safety rules could result in serious injury or death.

W A R N I N G

Basic safety precautions should always be followed when using lawnmowers in order to reduce the risk of fire, electric shock, and personal injury.

W A R N I N G

Use of this mower should be restricted to individuals who have read and understand and will follow the warnings and instructions that are printed in this manual and on the mower.

W A R N I N G

- Carefully read all instructions on the mower and in the manual before attempting to assemble and operate the mower.
 - For safe operation, read, understand, and follow all instructions in this manual.
 - Become familiar with all controls and their proper operation. Know how to stop the mower and how to disengage the power in an emergency.
 - Keep this manual in a safe place for reference and consult it regularly.
-

OPERATOR

- Only allow responsible, capable adults who are familiar with the instructions to operate this machine.
- Safe operation requires your full attention and capabilities.
- Always look where you are going and be aware of your surroundings.
- Listen to the machine and be aware of any change.
- Feel-the machine and its responses from both your inputs and the environment.
- Remain-focused on your task.
- Always wear proper eye protection that complies with the latest safety standards in order to reduce the risk of eye injury while operating or performing any adjustment or repair. See ANSI Z87.1.
- Always wear a face mask or a dust mask while operating the mower in a dusty environment.
- Always dress properly. The wearing of protective gloves and safety footwear is recommended.
- Do not wear radios or music headphones while operating the machinery.
- Do not operate the equipment while wearing sandals, tennis shoes, sneakers, shorts or any type of loose-fitting clothing. Long hair, loose clothing or jewelry may get tangled in moving parts. Always wear long pants, safety glasses, ear protection and safety shoes while operating this machine.
- Stay alert! Do not operate the mower when you are tired. Do not operate the mower while under the influence of alcohol or drugs. Pay attention to what you are doing. Use common sense.

SAFETY INFORMATION

MACHINE

- Never operate a poorly maintained machine.
- Always keep safety shields and covers in place.
- Follow daily and weekly checklists, making sure electrical connections are secured and bolts are tightened.
- Replace damaged parts immediately.
- Never operate mower without a proper trail shield, discharge cover, switch control, or other safety device in place and in working order. Do not operate the mower with damaged safety devices; doing so can result in injury.
- Repair or replace any damaged components before restarting and operating the lawnmower.
- Inspect lawnmower cord periodically and if damaged, have it repaired by an authorized service facility.
- Only use approved replacement parts.

MOWING AREA

- Before mowing any area, thoroughly inspect the area for any hazards. Walk the area to ensure there is adequate traction and no holes, drop-offs, or hidden objects that could cause issues. Clear the area of objects such as rocks, wire, toys, etc., which could be thrown by the blades.
- Be sure the area is clear of bystanders before operating. Stop machine if anyone enters the area.
- Plan your mowing pattern in such a way as to avoid discharging material toward roads, sidewalks, bystanders, vehicles, windows, etc. Do not discharge material against a wall or obstruction. Doing so may cause the discharged material to ricochet back toward the operator.
- Do not mow anything but grasses.
- Stop the blades when crossing dirt, gravel, or paved surfaces.
- Avoid dangerous environments. Do not operate the mower in the rain or in wet or damp grass. To reduce the risk of electric shock, do not expose to water or operate on wet ground.

MOWING

- For riding mower models, always remain seated while operating machine.
- Do not operate on inclines greater than 15 degrees.
- Mow only in daylight or in good artificial light. Never rush a mowing job.
- Never attempt high-speed maneuvering, especially in crowded, congested areas or on slopes.
- Do not operate within 100 ft. of people or animals. Do not mow when children or others are around.
- Look down and behind before and while moving backwards.
- Slow down before turning.
- Do not mow in reverse unless absolutely necessary.
- When moving in reverse, SLOWLY pull right and left Drive Control Levers rearward and avoid sudden movements. Rapid movement of the Drive Control Levers in either direction could result in a reaction of the machine that can cause serious injury.
- Do not put hands or feet near rotating parts or under the cutting deck. Contact with the blade can amputate hands and feet.
- If the mower starts to vibrate excessively, stop the motor and check for the cause immediately. Excessive vibration is generally a sign the mower is not functioning properly.
- Stop the motor and wait until the blade comes to a complete stop before unclogging the chute. The cutting blade will continue to rotate for a few seconds after the motor is shut off. Do not place any part of your body in the blade area until you are sure that the blade has stopped rotating.
- Disengage blade(s) when not mowing. Shut off engine and wait for all parts to come to a complete stop before cleaning the machine or unclogging the discharge guard.
- If lawnmower strikes a foreign objects, stop the machine, rotate the ignition switch to "OFF" position, then if it is safe, inspect for damage.

SAFETY INFORMATION

SERVICING

- Turn off the machine before servicing or removing blade.
- Do not reach under blade guard. Keep Hands, Feet, And Clothing Away From Rotating Blades.
- To reduce risk of injury to persons, remove battery pack when not in use.
- To reduce personal risk and damage to the machine, never clean with pressure washer.

CHARGING

- Do not recharge batteries in a confined or unventilated area.
- Do not smoke, strike a match, or cause a spark in the vicinity of the battery during charging.
- Store indoors, and do not expose to rainwater. Avoid storing in direct sunshine.
- Do not charge batteries in rain or in wet location.
- Double insulation - When servicing, use only identical replacement parts.
- Only to be used with Greenworks 82V Batteries(2919002). See Parts Manual.
- Electrical maintenance should be performed by trained professionals ONLY
- Never carry passengers.
- In order to avoid contact with the blade or injury caused by a thrown object, stay in the operating zone behind the handles, and keep children and bystanders at least 100ft (30m) away from the mower while it is in operation. Stop the motor immediately if someone enters the mowing area.
- Do not use the mower for any job except that for which it is intended.
- Don't force the lawnmower.
- Always store your lawnmower indoors. When not in use, the mower should be stored indoors in a dry and locked place, out of reach of children.
- Maintain your mower. Keep cutting edges sharp and clean to ensure the best performance and safe operation.
- Remove or disconnect battery before servicing, cleaning or removing material from lawnmower.
- Do not open or mutilate the battery. Mutilated batteries can release corrosive electrolytes which can cause damage to the eyes or skin. It may be toxic if swallowed.
- When using, keep out of water, extended periods of direct sunlight, and do not expose to rain.
- Store indoors in a secure, dry environment.
- Do not operate machine unless discharge guard or other safety devices are in place and working.
- Follow the manufacturer's recommendation for wheel weights or counterweights.

WARNING

Store indoors only. Always turn off the mower when cleaning or storing.

SLOPE OPERATION

Slopes are a major factor related to loss of control and tip-over accidents, which can result in severe injury or death. Operation on all slopes requires extra caution. If you cannot back up the slope or if you feel uneasy on it, do not mow it.

- Mow up and down slopes, not across.
- Watch for holes, ruts, bumps, rocks, or other hidden objects. Uneven terrain could overturn the machine. Tall grass can hide obstacles.
- Choose a low ground speed so you will not have to stop or shift while on a slope.
- Do not mow on wet grass. Tires may lose traction.
- Always keep the machine in gear when going down slopes. Do not shift to neutral and coast downhill.
- Avoid starting, stopping, or turning on a slope. If the tires lose traction, disengage the blade(s) and proceed slowly straight down the slope.
- Keep all movement on slopes slow and gradual. Do not make sudden changes in speed or direction, which could cause the machine to roll over.
- Use extra care while operating machine with attachments; they can affect the stability of the machine.

SAFETY INFORMATION

Do not use on steep slopes.

- Do not try to stabilize the machine by putting your foot on the ground.
- Do not mow near drop-offs, ditches or embankments. The machine could suddenly roll over if a wheel goes over the edge or if the edge caves in.

CHILD SAFETY

Tragic accidents can occur if the operator is not aware of the presence of children. Children are often attracted to the machine and the mowing activity. Never assume that children will remain where you last saw them.

- Never leave machine unattended with key in switch, especially with children present.
- Keep children out of the mowing area and under the watchful care of a responsible adult other than the operator.
- Do not allow children under the age of 14 to operate this mower. Children who are 14 years of age and older must read and understand the operating instructions and safety rules in this manual, and must be trained and supervised by a parent.
- Always disengage deck blade switch and turn key to "OFF" position and remove key.
- Stay alert, and turn the mower off if a child or any other person enters the mowing area.
- Use extreme care when approaching blind corners, doorways, shrubs, trees, or other objects that may obscure your view of a child who may run into the path of the mower.
- Before and while backing, look behind and down for small children.
- Never carry children on the mower with you, even with the blade(s) shut off. They may fall off and be seriously injured or interfere with safe machine operation. Children who have been given rides in the past may suddenly appear in the mowing area for another ride and be run over or backed over by the machine.

USING A RAMP

- Use extreme caution when loading and unloading this mower onto a truck or trailer with a ramp.
- Use only a single, full-width ramp. This provides a surface for the mower frame to contact if the unit starts to tip backwards. It also reduces the risk of a wheel going off and the machine tipping over.
- Do not exceed a 15-degree angle between the ramp and the ground or between the ramp and the trailer or truck.
- Become familiar with the mower's controls and confident in its smooth operation before attempting to drive it up or down a ramp.
- Use slow drive mode and drive carefully.
- Avoid any sudden movement of the controls and use only slow, even acceleration.

TOWING

- Tow only with a machine that has a hitch designed for towing. Do not attach towed equipment except at the hitch point.
- Follow the manufacturer's recommendation for weight limits for towed equipment and towing on slopes.
- Never allow children or others in or on towed equipment.
- On slopes, the weight of the towed equipment may cause loss of traction and loss of control.
- Travel slowly and allow extra distance to stop.

SAFETY INFORMATION

BATTERY & CHARGER

CAUTION









Use only Greenworks Commercial approved replacement batteries, as other batteries may cause injury or damage to the mower. Only to be used with Greenworks Commercial 82V Batteries.

BATTERY SAFETY RULES

- Battery-operated mowers and tools do not have to be plugged into an electrical outlet; therefore, they are always in operating condition. Be aware of possible hazards when not using your battery-operated mower or when changing accessories. Following this rule will reduce the risk of electric shock, fire, or serious personal injury.
- Do not place battery-operated machines or tools -- or the batteries themselves -- near fire or heat. This will reduce the risk of explosion and possibly injury.
- Do not crush, drop or damage battery pack. Do not use a battery pack or charger that has been dropped or received a sharp blow. A damaged battery is subject to explosion. Properly dispose of a dropped or damaged battery immediately.
- Batteries can explode in the presence of a source of ignition, like a pilot light. To reduce the risk of serious personal injury, never use any cordless product in the presence of an open flame. An exploded battery can propel debris and chemicals. If exposed, flush with water immediately. Do not charge battery tool in a damp or wet location. Following this rule will reduce the risk of electric shock.
- For best results, your battery-operated machine should be charged in a location where the temperature is more than 0°C (32° F) but less than 45°C (113° F). To reduce the risk of serious personal injury, do not store outside or in vehicles.
- Under extreme usage or temperature conditions, battery leakage may occur. If this liquid comes in contact with your skin, wash immediately with soap and water. If liquid gets into your eyes, flush them with clean water for at least 10 minutes, then seek immediate medical attention. Following this rule will reduce the risk of serious personal injury.
- When battery pack is not in use, keep it away from other metal objects like paper clips, coins, keys, nails, screws, or other small metal objects that can make a connection from one terminal to another. Shorting the battery terminals together may cause sparks, burns, or a fire.
- Battery posts, terminals, and related accessories may contain lead and lead compounds, chemicals known to the State of California to cause cancer and reproductive harm. Wash hands after handling.
- Charge batteries in an open, well-ventilated area away from spark and flames. Unplug charger before connecting or disconnecting battery to/from the charging port. Always wear safety glasses and protective clothing/gear. Use insulated tools.
- Sparks can cause a battery gas explosion, which will result in serious personal injury. Prevent the battery terminals from touching any metal mower parts when removing or installing the battery. Do not allow metal tools to short between the battery terminals and metal mower parts. Use insulated tools. Always keep protective battery cover and rear cover in place.
- Explosive gases from batteries can cause serious injury, or death. Poisonous battery fluid contains sulfuric acid; contact with skin, eyes or clothing can cause severe chemical burns.
- Follow first aid directions for contact with battery fluid. Get medical attention immediately.
- Incorrect battery cable routing could cause damage to the mower and battery cables. This can cause sparks, which can cause a battery gas explosion that will result in serious personal injury.



SYMBOLS

Some of the following symbols may be used on this product. Please study them and learn their meaning. Proper interpretation of these symbols will allow you to operate the product better and safer.

SYMBOL	NAME	DESIGNATION/EXPLANATION
V	Volts	Voltage
A	Amperes	Current
Hz	Hertz	Frequency (cycles per second)
W	Watts	Power
min	Minutes	Time
—	Direct Current	Type or a characteristic of current
n_0	No Load Speed	Rational speed - at no load
/min	Per Minute	Revolutions, strokes, surface speed, orbits etc., per minute
	Safety Alert	Indicates a potential personal injury hazard.
	Wet Conditions Alert	Do not expose to rain or use in damp locations.
	Read The Operator's Manual	To reduce the risk of injury user must read and understand operator's manual before using this product.
	Eye Protection	Always wear safety glasses with side shields that are marked to comply with ANSI Z87.1.
	Keep Hands and Feet Away	Keep hands and feet away from blade and cutting area.
	No Reach	Do not reach hands or feet under mower deck.
	No Slope	Do not operate on inclines greater than 15°. Mow across the face of slopes, never up and down.
	Keep Bystanders Away	Keep all bystanders at least 100 ft. away.
	Ricochet	Pay attention that bystanders are not injured through foreign objects thrown from the mower.

SYMBOLS

The following signal words and meanings are intended to explain the levels of risk associated with this product.

SYMBOL	SIGNAL	MEANING
	DANGER	Indicates an imminently hazardous situation, which, if not avoided, will result in death or serious injury.
	WARNING	Indicates a potentially hazardous situation, which, if not avoided, could result in death or serious injury.
	CAUTION	Indicates a potentially hazardous situation, which, if not avoided, may result in minor or moderate injury.
	CAUTION	(Without Safety Alert Symbol) Indicates a situation that may result in property damage.

SERVICE

Servicing requires extreme care and knowledge and should be performed only by a qualified service technician. For service, we suggest you return the product to your nearest **AUTHORIZED SERVICE CENTER** for repair. When servicing, use only identical replacement parts.

W A R N I N G

To avoid serious personal injury, do not attempt to use this product until you have read this Owner's Manual thoroughly and understand it completely. If you do not understand the warnings and instructions in this Owner's Manual, do not use this product. Call the toll-free helpline (1-855-470-4267) for assistance.

W A R N I N G



The operation of any power tool can result in foreign objects being thrown into your eyes, which can result in severe eye damage. Always wear safety goggles or safety glasses with side shields and, when needed, a full face shield. We recommend a Wide Vision Safety Mask for use over eyeglasses or standard safety glasses with side shields. Always use eye protection which is marked to comply with ANSI Z87.1.

SAVE THESE INSTRUCTIONS

KNOW YOUR ZERO TURN MOWERS

KNOW YOUR MOWER

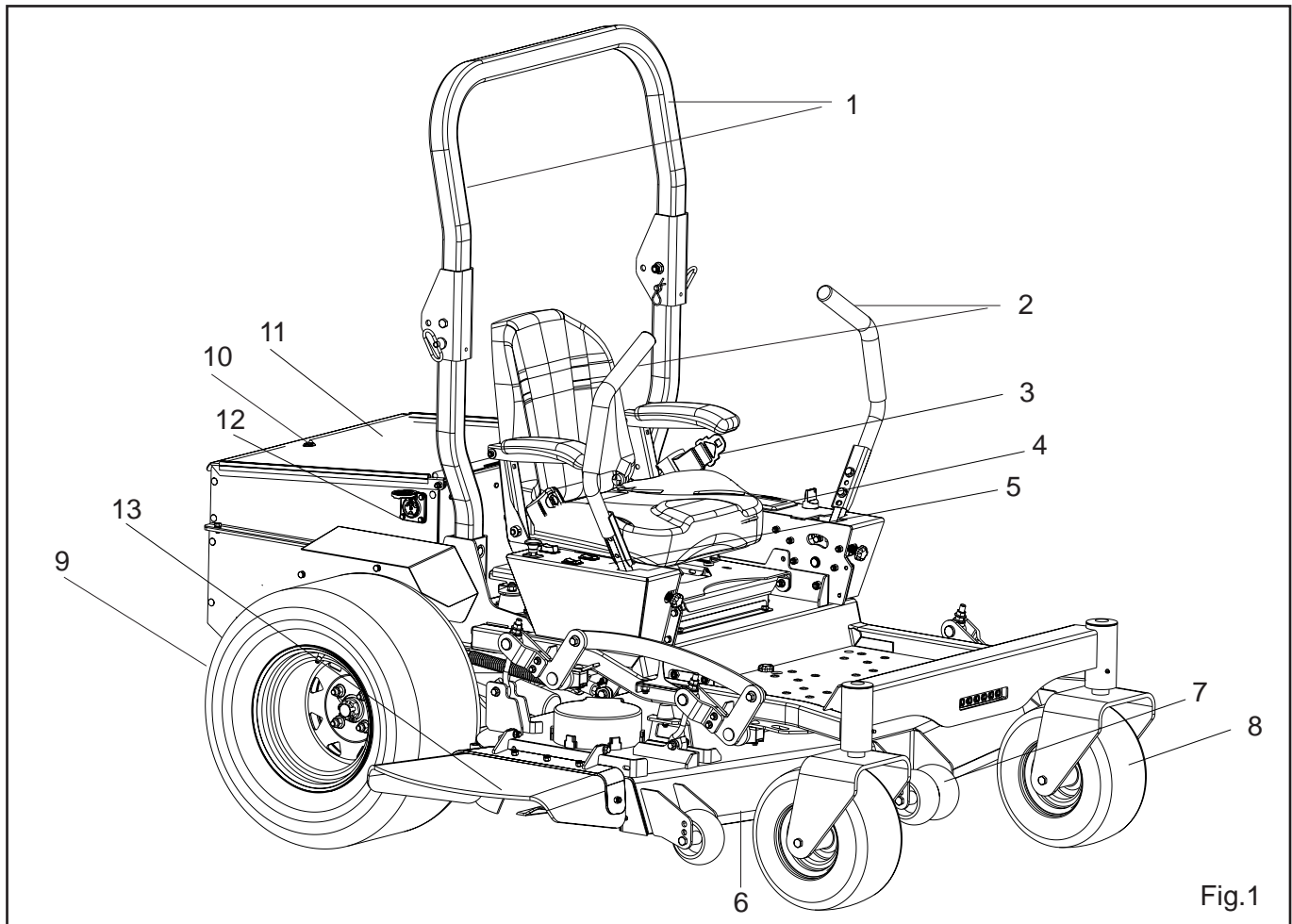

See Figure 1.

No.	Name	No.	Name
1	ROPS (Roll Over Protective Structure)	8	Front wheel
2	Steering control levers	9	Drive wheel
3	Safety belt	10	Key of battery pack protection
4	Left control panel	11	Battery pack protection
5	Right control panel	12	Charging port
6	Deck	13	Discharge chute
7	Anti-scalp wheels		

KNOW YOUR ZERO TURN MOWERS

CONTROL PANEL

Left control panel (with operator seated) (See Figure 2.)

- **Digital display:** This display shows important electrical system information. Refer to the *Electrical section* for complete information.
- **Master power ignition switch:** a two position switch: OFF and ON. With key inserted, rotate it clockwise to the ON position; counterclockwise to OFF position.

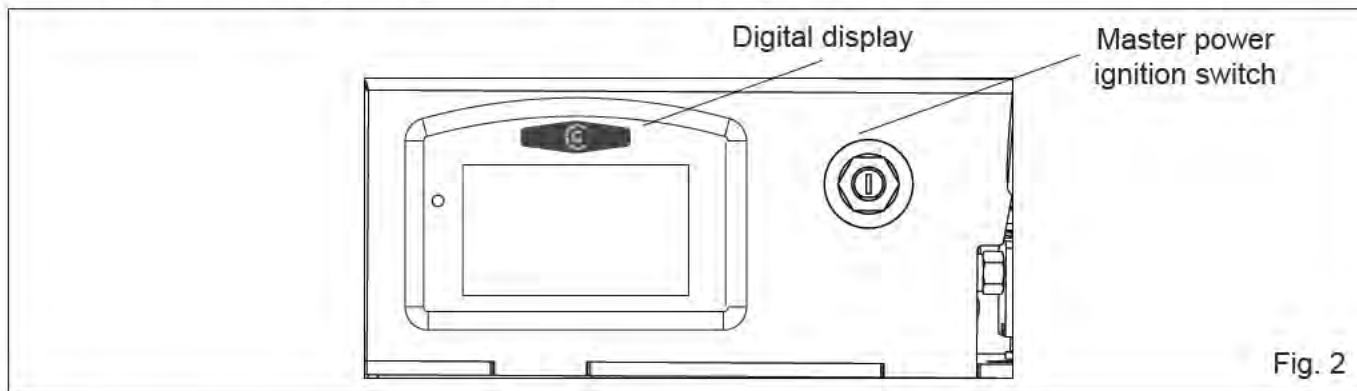

Fig. 2

Right control panel (with operator seated) (See Figure 3.)

- **Drive speed control button:** Allows operators to select a comfortable driving speed. Pressing it to “High Speed” position means that the maximum drive speed will be 10 mph. Pressing it to “Low Speed” position means that the maximum drive speed will be 6 mph. Press it to “Low Speed” position for inexperienced operators or when trimming around objects, buildings and other obstacles.

Note: Get comfortable with mower before using “High Speed” setting. The maximum speed may be adjusted at any time, whether the mower is in motion or not.

- **Hi/Lo blades speed button:** High blade mode is a higher blade speed for cutting thicker grass, while low blade mode provides lower blade speed for lower battery consumption on thinner, drier grass areas.

Note: Mowing time will be increased when mowing in low blade mode.

- **Deck height button:** Adjust the height of mower deck.
- **Deck blades On and OFF switch:** This switch engages the deck motors. Pull the switch up to engage and push switch down to disengage the motors.

Important: Never engage deck motors when the deck is under load. Motors or deck could be damaged.

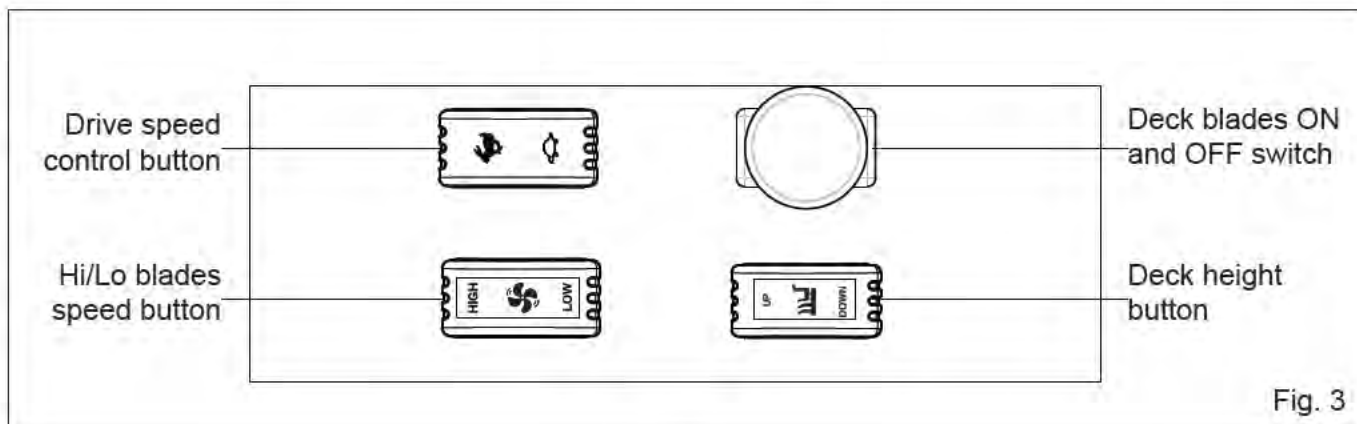

Fig. 3

KNOW YOUR ZERO TURN MOWERS

STEERING CONTROL LEVERS (See Figure 4.)

- The two levers control the mower's speed, direction, stopping, neutral lock, and park brake. Levers are used to steer, accelerate, decelerate, stop, and change direction. When the control levers are in the park brake position, the mower will not move when the drive system is operating.

STEERING ALIGNMENT SCREW (See Figure 4.)

- The two screws control the maximum steering speed when the mower goes forward. When the screws are rotated clockwise, the maximum speed will be increased.

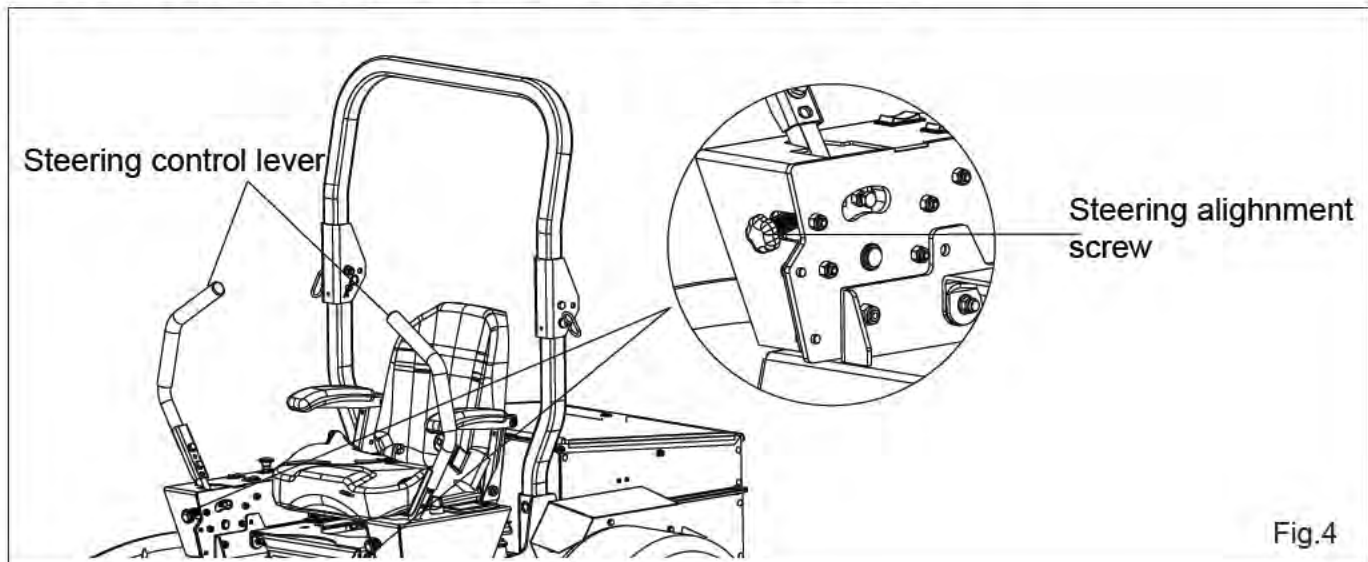

SAFETY START INTERLOCK SYSTEM

The machine is equipped with a safety start interlock system consisting of the park brake switches, seat switch, and deck blades ON and OFF switch.

The mower's safety start interlock system is also designed to protect the operator and others from accidental injury due to unintentional traction drive system starting.

Check mower safety start interlock system daily, prior to operation. This system is an important mower safety feature. It should be repaired immediately if it malfunctions. Call Greenworks Commercial immediately. The machine incorporates a separate seat switch which will stop the drive system and deck motors when the operator is unseated for any reason while the mower is operating. This is a safety feature designed to prevent runaway or accidental entanglement.

⚠ WARNING

The safety interlock system must not be disconnected or bypassed. Doing so could cause the machine to operate unexpectedly, resulting in personal injury.

To inspect the system:

1. The operator must be on the seat when testing the seat switch.
2. Turn the master power ignition switch to the ON position with key.
3. Keep steering control levers in neutral position.
4. Pull the deck blades ON and OFF switch to engage the motor.
5. Slowly raise off of the seat. The deck blade system should stop.
6. If the deck blade system fails to stop when the operator is off of the seat and if the cause cannot be determined, contact your Greenworks dealer immediately.

KNOW YOUR ZERO TURN MOWERS

ROPS (Roll Over Protective Structure) (See Figure 5.)

A ROPS may minimize the chance of injury or death from rollover.

The two-post ROPS can be pivoted down by removing the clevis pins after pulling out on the R-pins (Fig. 3-5) so that the machine can operate under low-hanging tree limbs or other obstructions. Do not wear the seat belt when the ROPS is in the lowered position. Use the ROPS in the “folded” position only when it is absolutely necessary.

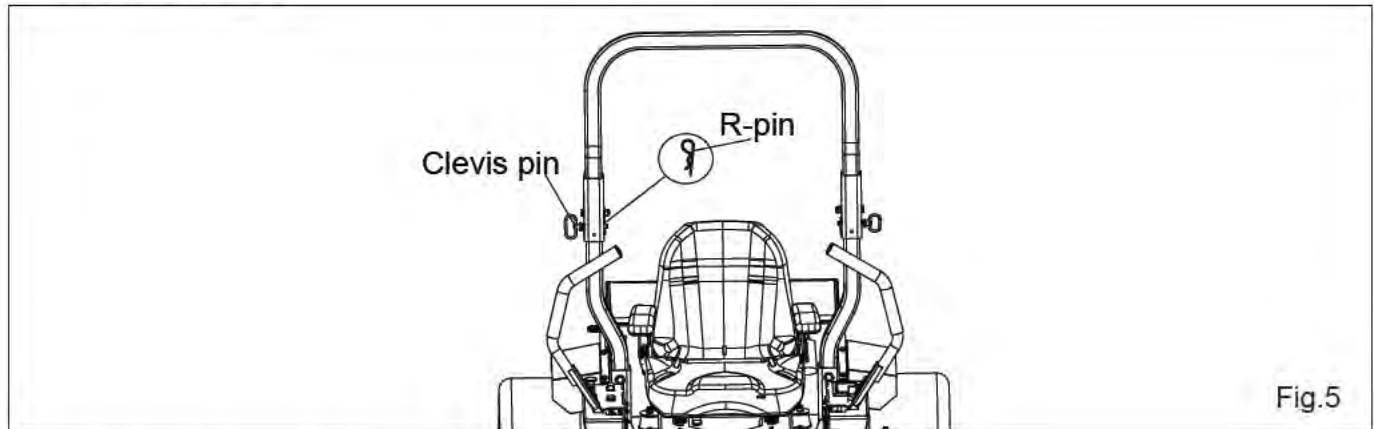

⚠ WARNING

Do not operate the mower with the ROPS folded (lowered position) -- a standard operating mode. A folded ROPS does not provide rollover protection.

⚠ WARNING

Always wear your seat belt unless the ROPS is folded down. In this case, the seat belt should never be worn.

⚠ WARNING

To minimize chance of injury or death from rollover:

Keep ROPS in the raised and locked position and use the seat belt.

Never operate machine on a slope with the ROPS folded down (lowered position).

There is no rollover protection when the ROPS is in the lowered position.

Lower the ROPS only when absolutely necessary.

Drive slowly and carefully. Raise the ROPS as soon as clearance permits. Read and follow slope operation instructions and warnings.

Do not wear seat belt when the ROPS is in the lowered position.

⚠ WARNING

Always pull from the tractor hitch. Do not attach chains or ropes to the ROPS for pulling purposes, as the machine can tip backwards.

Always fasten seat belt during operation of the machine (mower equipped with ROPS in “raised/up” position).

Inspect the area to be mowed for proper overhead clearance (tree limbs, guy wires, doorways, etc.)

Do not contact any overhead object with the ROPS.

KNOW YOUR ZERO TURN MOWERS

WORK LIGHT (See Figure 6.)

The work light is located on the front center of the mower. It will light up automatically when light cannot be fully sensed by photo-diode, and it will go out when light can be sensed by photo-diode.

NOTE: The light cannot serve as the drive light.

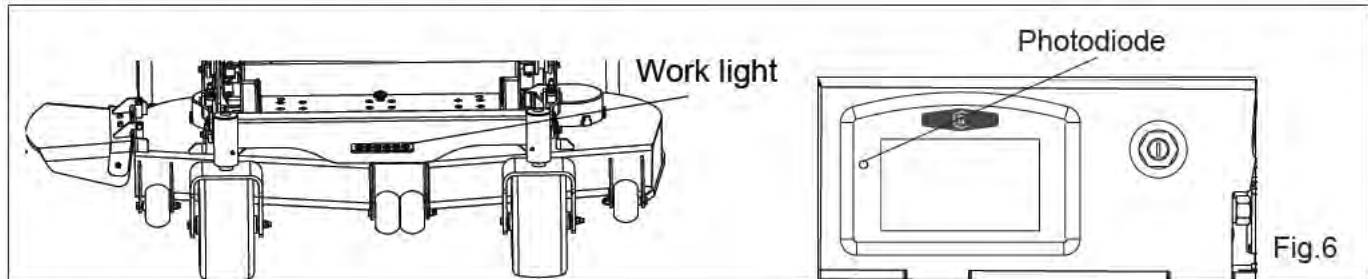

ANTI-SCALP WHEELS (See Figure 7.)

Anti-scalp wheel kits are standard on Greenworks Commercial units. These anti-scalp wheels are designed to minimize scalping when mowing on rough, uneven terrain. After setting the cutting height, adjust the anti-scalp wheels so they extend below the deck but do not contact the ground. They should always be at least 1/4" to 3/4" below the deck. With the unit sitting on a flat level surface, the wheel position can be adjusted up or down as needed from 3/4" to 1-3/4" below the blade surface. Move the wheels up or down - using the different axle mount holes in the wheel mount bracket (if applicable on model).

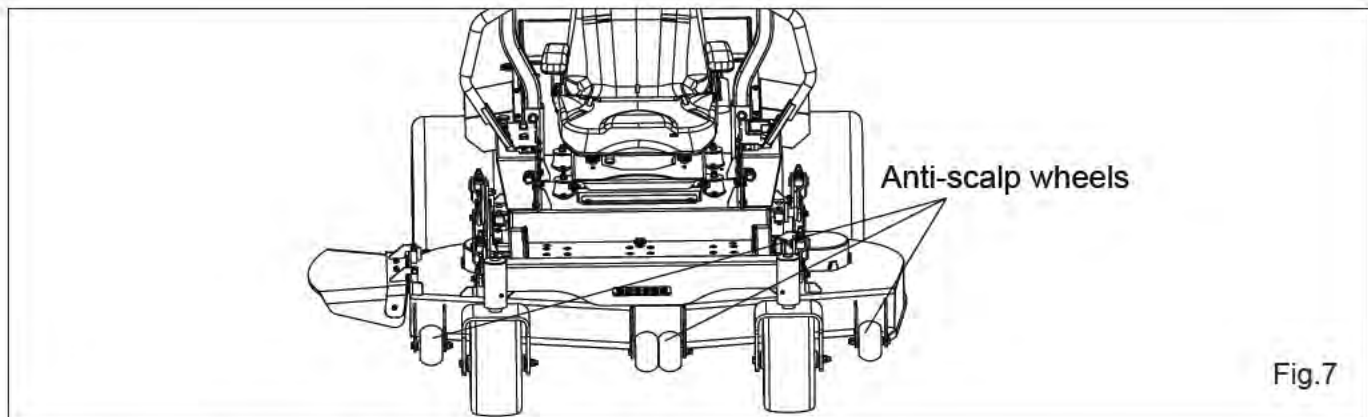

IF TOWING OR MANUAL PUSHING IS NEEDED:

Be sure that the mower is in neutral and that the wheels are chocked. Locate the Neutral Bypass Knobs behind the frame at the rear of the mower. Remove the (4) thumb screws holding in the mesh cover.

NEUTRAL BYPASS KNOB (See Figure 9.)

- Remove the neutral bypass from its original location and install it to the motor. Operate one or both of the knobs on the motor, as needed.
- Rotate the neutral bypass knobs clockwise to release drive brakes; counterclockwise to engage.
- Install the neutral bypass knob(s) back to its/their original location after completing maintenance.

⚠ WARNING

Never drive mower with the neutral bypass knob working. Always install the neutral bypass knob to the original position before driving! Failure to re-install the knob could cause serious damage to your mower and void mower warranty!

KNOW YOUR ZERO TURN MOWERS

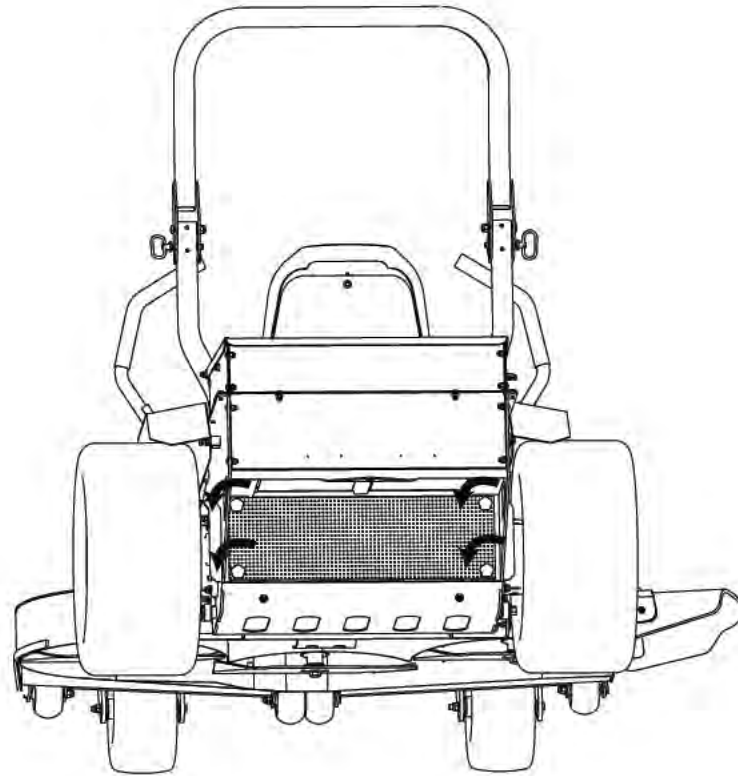
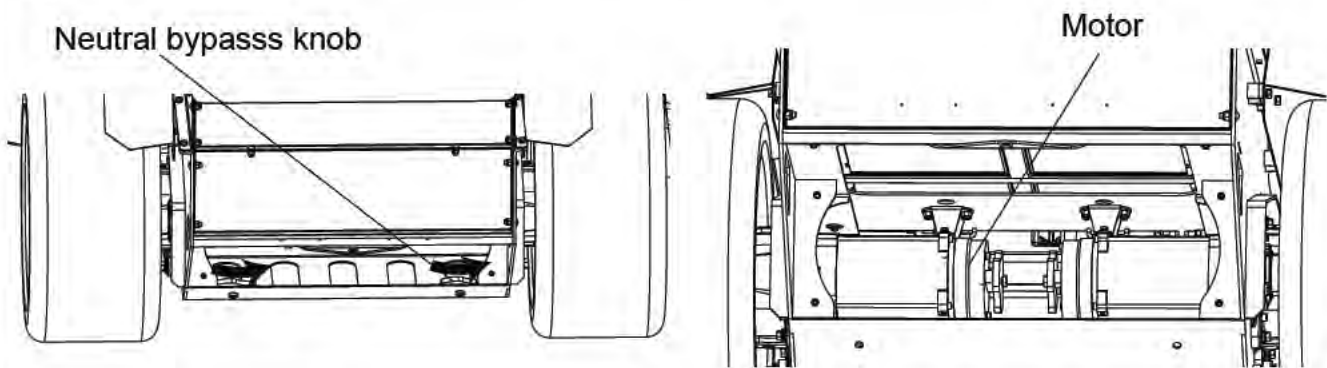

Fig.8

Fig.9



⚠ WARNING

Never pull the neutral bypass lever outside when the machine is working on the slope!

OPERATING YOUR LAWN MOWER

STARTING YOUR MOWER

⚠ WARNING

Seat belt must be fastened while operating a mower equipped with ROPS in the raised and secured position. Do not wear the seat belt when the ROPS is in the lowered position.

- With key inserted, turn master power ignition switch on by rotating key clockwise to the ON position.
- Check for the appropriate speed mode by pressing drive speed control button to “low speed” position.

NOTE: It is always recommended to start out in low mode/slow speed.

- Pull right and left drive control levers inward until stops are contacted.
- Pull up on deck blades ON/OFF switch to start cutting blades for mowing.

NOTE: only engage blades when drive control levers are in the NEUTRAL position! NEVER engage blades when moving!!

- Push drive control levers forward for forward motion and pull for reverse motion.

NOTE: Electric brake will engage after drive control levers are returned to neutral.

STOPPING YOUR MOWER

⚠ DANGER

Never make sudden stops or reverse direction, especially when maneuvering on a slope. The steering is designed for sensitive response. Rapid movement of the steering control levers in either direction could result in a reaction of the machine that can cause serious injury.

- Return drive control levers to the Neutral/Park brake position.
- Push down on deck blades ON/OFF to turn off the blades.
- Push drive control levers outward into park brake position.
- Rotate key in Master Power Ignition Switch counterclockwise to the OFF position.

DRIVING THE MOWER (See Figure 10.)

After starting the traction drive system, engage the steering control levers and steer as follows:

To go forward, push steering control levers forward an equal distance.

To go in reverse, pull steering control levers rearward an equal distance.

To turn left, move the right steering control lever farther forward from neutral than the left steering control lever.

To turn right, move the left steering control lever farther forward from neutral than the right steering control lever.

FRONT OF MOWER FACES THIS DIRECTION

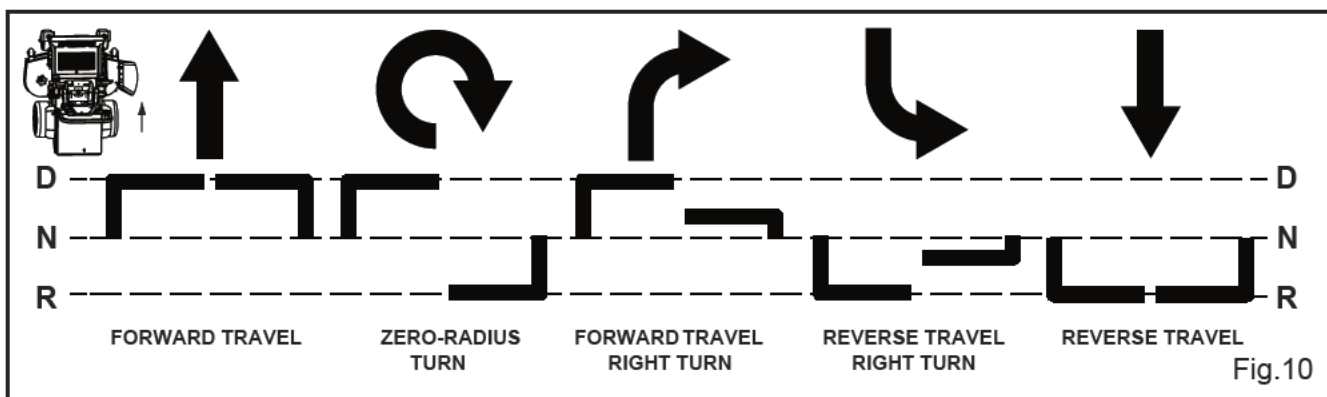

N = NEUTRAL POSITION D = DRIVE POSITION R = REVERSE POSITION

Direction of arrows indicate direction of mower movement

┌ Left steering control lever

└ Right steering control lever

OPERATING YOUR LAWN MOWER

To execute a zero-radius turn, move one steering control lever forward and the other steering control lever back of neutral. This will allow the drive wheels to counter-rotate. (See Figure 10)

To stop or decrease speed, move steering control levers to neutral. When going forward, pull back gently on steering control levers. When going in reverse, push forward gently on steering control levers.

For an emergency stop, there are two methods that can be used:

- When traveling forward or in reverse, place the steering control levers in the park brake position immediately. When moving in the rearward direction, push forward gently on steering control levers and avoid sudden movement. Any sudden movement could cause the front of the mower to come off of the ground, resulting in possible loss of control, thereby causing serious injury or death.
- Turn the ignition key to the OFF position. This will shut down the traction drive system and the deck drive system.

To make a three-point turn to the right, move the left steering control lever farther forward from neutral than the right steering control lever and start the turn. Next, pull back on the steering control levers until they are past neutral and the machine starts to go rearward. Pull the right steering control lever farther rearward from neutral than the left steering control lever until the rear of the machine has pivoted around. Then, push the steering control levers forward until they are both past neutral and the machine starts to go forward. Push the left steering control lever farther forward from neutral than the right steering control lever and finish the turn.

⚠ WARNING

Always be aware of what is behind the machine before backing up. Do not mow in reverse unless absolutely necessary. Always look down and behind before and while backing up.

⚠ IMPORTANT

Rapid movement of steering control levers is not recommended as damage to the electrical system components may occur.

To increase speed, increase steering control lever's distance from neutral. The farther forward steering control levers are from neutral, the faster the machine will travel forward. The farther back steering control levers are from neutral, the faster the machine will go in reverse.

STEERING CONTROL LEVER ADJUSTMENT (See Figure 11.)

The steering control levers can be adjusted for operator comfort. By loosening the cap screws that attaches the upper control lever to the lower lever, the upper control lever can be pivoted to fit the operator's personal preference. The steering control levers should be adjusted so that they align with each other when in the neutral position.

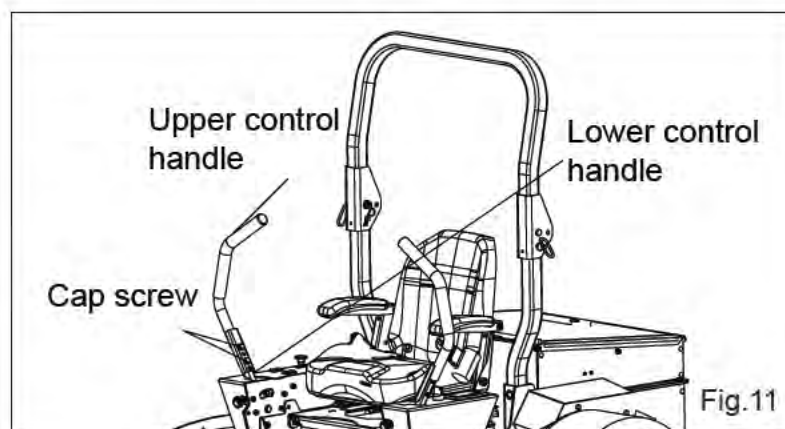

OPERATING YOUR LAWN MOWER

SEAT ADJUSTMENT (See Figure 12.)

⚠ WARNING

Make sure seat pan is securely bolted down prior to each use to prevent seat from moving/tilting in the event of mower tipping or rollover.

The seat can be adjusted forward and rearward by moving the latch under the seat. Move the latch to left and pull the seat where you have the best control of the machine and are the most comfortable and then tighten the safety belt.

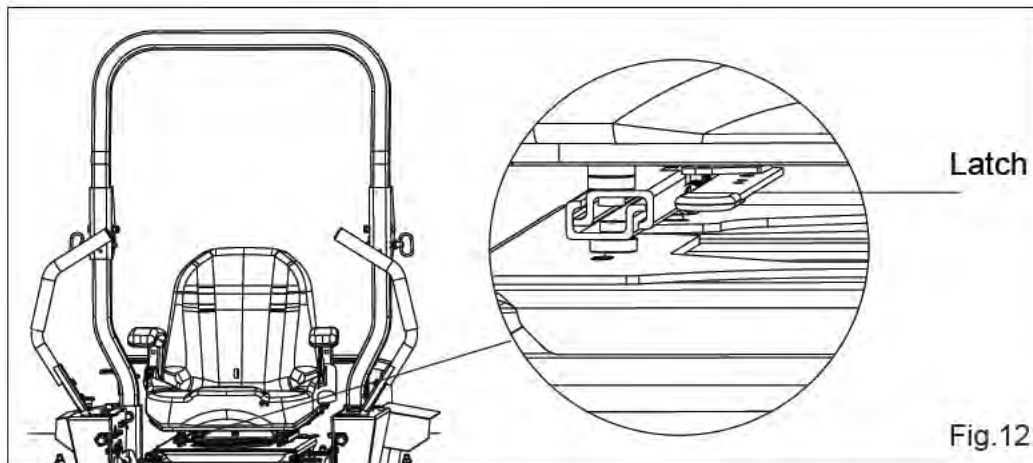

DECK CUTTING HEIGHT ADJUSTMENT

⚠ DANGER

Never attempt to make any adjustments to the mower deck while the traction drive system is on or with the deck clutch engaged. Mower blades cannot be seen and are located very close to deck housing. Fingers and toes can be cut off instantly.

Deck height is adjustable from 1" - 6" (3.33 cm - 20 cm). Deck should be raised while mowing is in progress to avoid stumps, rocks or other obstacle that can be damage mower deck.

- Deck height will be decreased when deck height button is pressed to "low" position.
- Deck height will be increased when deck height button is pressed to "high" position.

OPERATING SUGGESTIONS

⚠ DANGER

Prior to operation, the operator should be thoroughly familiar with the proper use and operation of the equipment, should read the manual completely and thoroughly, and should have attempted slowmoving maneuvers to become familiar with the operation of the equipment before attempting normalspeed operation. An inexperienced operator should not mow on slopes or on uneven terrain.

⚠ WARNING

If you lose steering control while operating the machine, place the steering control levers in the park brake position immediately and turn key to the "OFF" position. Inspect the machine and consult your Greenworks Commercial dealer to resolve the problem before continuing to operate.

⚠ WARNING

The unit's steering control levers are very responsive. For smooth operation, move levers slowly, avoiding sudden movements. Skill and ease of operation come with practice and experience. The machine can spin very rapidly. Use caution when making turns and slow down before making sharp turns.

OPERATING YOUR LAWN MOWER

Inexperienced operators may have a tendency to oversteer and lose control. Slow-moving practice maneuvers are recommended to become familiar with these characteristics before attempting normal-speed operation.

⚠ W A R N I N G

Sharp depressions or raised obstacles (such as gutters or curbs) should not be directly approached at high speed in an attempt to “jump” them as the operator could be thrown from the equipment. Approach at a slow speed and angle one drive wheel at the obstruction. Continue at an angle until the wheel clears and then pivot the opposite wheel around.

When turning on soft, wet turf, keep both wheels rolling either forward or backward. Pivoting on one stopped wheel can damage turf. This is especially important when mowing. Keep blades sharp. Many professional mowing companies have additional sets of blades and change blades twice a day: once in the morning and again at noon. Many problems with incorrect cutting patterns are due to dull blades or blades which have been sharpened incorrectly. Information on sharpening blades is listed in this manual’s maintenance section. In addition, most communities have individuals or companies that specialize in sharpening mower blades. Blade sharpness should be checked daily.

⚠ D A N G E R

Never work with blades while key is in the ignition switch. Always place deck clutch switch in the disengaged position, place steering control levers in the park brake position and turn key to the OFF position and remove key from switch. Block up mower when you must work under it. Wear gloves when handling blades. Always check for blade damage if mower strikes a rock, branch, or another foreign object during mowing.

Direct grass discharge to right, away from unmown area. Select a mowing pattern that directs grass discharge towards the outside the mowing area. Generally, this means using a pattern utilizing left turns because side discharge is to the right. In any case, avoid throwing grass discharge onto unmowed area because grass is then mowed “twice.” Mowing twice puts an unnecessary load on the unit and reduces mowing efficiency.

When mowing a lawn for the first time, cut grass slightly longer than normal to avoid scalping uneven terrain. When possible, it is best to use the cutting height that was used in the past. When cutting grass taller than six inches, you may want to mow the lawn twice to achieve a better quality of cut.

During normal mowing, cut only about 1/3 of the grass blade. Cutting more than that is not recommended unless grass is sparse or it is the end of the mowing season.

Alternate mowing direction to keep the grass growing straight and better dispersion of the clippings.

Remember, grass grows at different rates at different time of the year. Mow more often in the early spring to maintain the same cutting height. As the growth rate slows in mid summer, mow less frequently. If you cannot mow at a regular interval, mow at a high cutting height at first, then mow again two days later at a lower cutting height.

Raise the cutting height of the mower if the cutting width of the mower is wider than the previous mower. This ensures that uneven turf is not cut too short.

Raise the cutting height of the mower if the grass is slightly taller than normal or if it contains a high degree of moisture. Then mow it again with the cutting height set lower. If the machine’s forward motion must be stopped while mowing, a clump of grass clippings may drop onto your lawn. To avoid this, move onto a previously cut area with the blades engaged.

Charge the battery immediately. If battery percentage is higher than 2% and less than 5%, the maximum drive speed will be 6 mph and the unit will in low blade mode. If battery percentage is less than 2%, the working blade will stop automatically. The unit should immediately be returned to the battery charging area and the unit connected to the battery charger.

Allow motors 30-60 minutes to cool down. If drive motor exceeds programmed temperature, the motor speed will decrease. If temperature continues to increase, drive will shut down at a higher programmed temperature.

OPERATING YOUR LAWN MOWER

⚠ W A R N I N G

Never direct discharge of material from mower deck towards bystanders. Do not operate the mower without either the discharge chute or the entire grass collection system in place.

SLOPE OPERATION

REMINDER: Only operate on slopes of 15 degrees or less. Slopes are a major factor in loss-of-control and tip-over accidents, which can result in severe injury or death. All slopes require extra caution. If you cannot back up the slope or if you feel uneasy on it, do not mow it.

- Use extreme caution when operating on slopes.
 - Be extremely careful changing directions on a slope. Slow down.
 - Do not operate where the machine could slip or tip.
 - Turn slowly.
 - Turn on the most level part of the slope.
 - To maximize traction, it is better to turn the front of the machine uphill, rather than downhill. If drive tires lose traction, steering control can be lost which could cause serious injury or death.
 - If it becomes necessary to turn downhill, do so slowly and gradually.
- Do not remove or modify the stabilizer wheels.
- Watch for holes, ruts, bumps, rocks or other hidden objects. Uneven terrain could overturn the machine. Tall grass can hide obstacles.
- Remove obstacles such as rocks, tree limbs, etc.
- Keep all movement on slopes slow and gradual. Do not make sudden changes in speed or direction.
- Avoid starting and stopping on a slope. If tires lose traction, disengage the blades and proceed slowly straight down the slope.
- Mow a safe distance (minimum of 10 feet, or 3.05 meters) away from drop-offs, retaining walls, drainage ditches, embankments, water, and other types of hazards to avoid a wheel dropping over the edge or the ground breaking away. This will reduce the risk of the machine suddenly rolling over, which could cause either serious injury or death.
- Use a walk-behind, push mower or hand-held trimmer on slopes and near drop-offs, retaining walls, drainage ditches, embankments and water to avoid machine rollover.
- Do not mow on wet grass. Reduced traction could cause sliding and loss of steering control.
- Do not tow on slopes. The weight of the towed equipment may cause loss of traction and control.
- If the mower's tires lose traction when operating on slopes, disengage the deck drive, place the steering control levers in the park brake position, turn the key to the "OFF" position and get help.
- Never make sudden starts, stops, turns, or reverse direction, especially when maneuvering on slopes. The steering is designed for sensitive response. Rapid movement of the steering control levers in either direction could result in a reaction of the machine that can cause serious injury.
- Never stop suddenly while backing down slopes. This action may result in a reaction of the machine that can cause serious physical injury.
- The Greenworks Commercial mower is capable of operating horizontally (traverse) on moderate slopes. When operating on slopes up to 15 degrees, be aware of any conditions that may cause the mower drive tires to lose traction, resulting in a possible loss of control of the machine. An operator should not operate on a slope until he is thoroughly familiar with the equipment.

Do not operate on slopes greater than 15 degrees.

Refer to Slope Guide, page 2-7, when determining the degree of slope to be mowed. It is strongly recommended that the operator drive the machine off of the slope, using extreme caution, if any sign of loss of traction is detected. Wait until the condition that caused the problem is resolved before attempting to operate on the slope again. Terrain conditions can affect traction, resulting in possible loss of control of the machine. Some of the conditions to be aware of are:

OPERATING YOUR LAWN MOWER

1. Wet terrain
2. Depressions in the ground (e.g., holes, ruts, washouts)
3. Mounds of dirt
4. Certain types of soil (e.g., sand, loose dirt, gravel, clay)
5. Grass type, density, and height
6. Extremely dry conditions
7. Tire pressure

The attachments mounted to the mower will also affect the way it handles on a slope. Be aware that each attachment's characteristics vary.

Another consideration is to always mow a safe distance (minimum of 10 feet/3 meters) away from drop-offs, retaining walls, drainage ditches, embankments, water, and other types of hazards to avoid a wheel dropping over the edge or to avoid the ground from breaking away and always be aware of what is located at the bottom of the slope. This will reduce the risk of the machine suddenly rolling over, causing serious injury or death. Extreme caution should be used when there is a hazard located at the bottom of the slope. Some examples are: water (e.g., lake, river), cliffs, retaining walls, roads, highways, buildings, rocks.

These are just a few examples of situations where caution must be used when operating on a slope. There are many other possibilities too numerous to mention. Remember to always exercise extreme caution while operating on any slope.

- The ROPS may minimize chance of injury or death from rollover. Seat belt must be fastened while operating a mower equipped with ROPS in the raised and secured position. Both retaining pins and hair pins must be installed. Failure to use seat belt with ROPS will result in serious injury in the event of a rollover.

OPERATING YOUR LAWN MOWER

SLOPE GUIDE

Use this diagram when determining the degree of slope to be mowed.

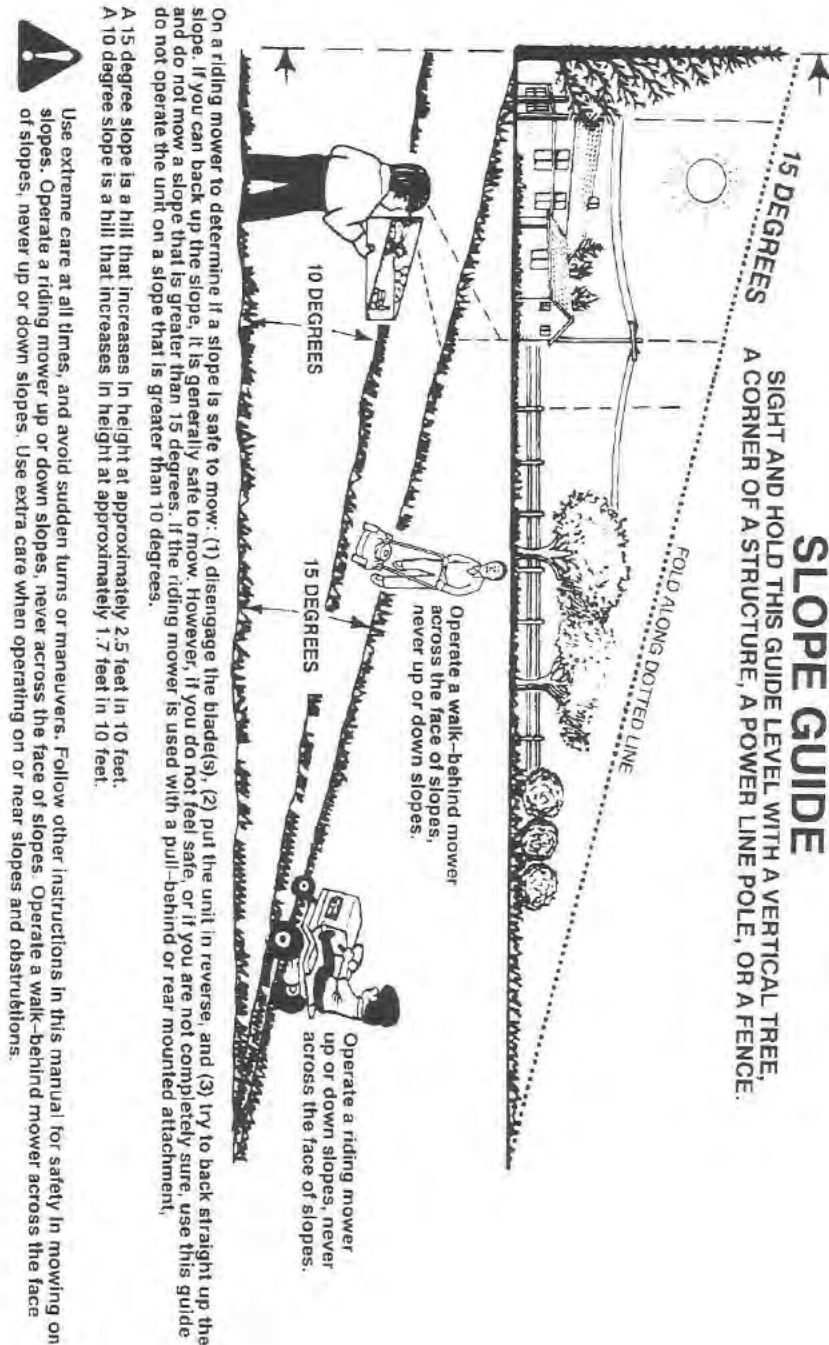

ELECTRICAL SYSTEM

ELECTRICAL SYSTEM SAFETY

- Remove key, disconnect battery cables by pulling inward on RED battery quick disconnect handle in battery box compartment and read owner's manual before adjusting or repairing unit.
- Always remove key and disconnect battery cables by pulling inward on RED battery quick disconnect handle in battery box compartment before working on this unit.
- Always disconnect battery cables by pulling inward on RED battery quick disconnect handle in battery box compartment when transporting unit.
- Keep unit free of grass clippings, leaves and other debris. DO NOT spray water to clean unit. Use only compressed air. Wear adequate eye and hearing protection when cleaning the unit.
- Always wear safety glasses and protective gear near battery. Use insulated tools.
- Clean battery compartment, drive motor compartment, mower deck, seat, etc., of all dirt and debris. Do not use solvents, hard cleaners or abrasives.
- With key in "ON" position, mower blade can engage when deck blade ON/OFF switch is engaged, even if drive motor is not turning. Keep area clear of bystanders when engaging deck blade ON/OFF switch.
- All maintenance and storage areas should be properly ventilated in accordance with applicable fire codes and ordinances to avoid fire hazards. Proper ventilation is required to remove hydrogen gas from the area during battery charging.
- Never allow flames, sparks or smoking near batteries.
- Keep batteries out of reach of children.
- Always keep protective shields, covers and guards in place and securely fastened. If they become damaged, repair or replace immediately. Never modify or remove safety devices.

ELECTRICAL SYSTEM INFORMATION

The Greenworks Commercial mower is powered by a 82-volt electrical system. It consists of the following components:

1. Deck controller (3) (Depending on model)
2. Deck Motor (3) (Depending on model)
3. Drive controller (2)
4. Accelerator - right (1)
5. Accelerator - left (1)
6. Digital battery display (1)
7. Integrated electric trans-axle (2)
8. Lithium Energy Modules (LEMs) (1)

BATTERY AND CHARGER

I M P O R T A N T

Maintenance for the various electrical components found on the Greenworks Commercial Mower should only be performed by a Greenworks Commercial Mower trained technician.

I M P O R T A N T

When battery voltage becomes low, the mower blades will stop, although the drive motors will continue to run, enabling driver to continue to drive unit. When the batteries discharge to this point, they require recharging. The unit should immediately be returned to the battery charging area and the unit connected to the battery charger.

W A R N I N G

Do not attempt to cross roads or railways with low battery levels.

ELECTRICAL SYSTEM

Battery charging port (See Figure 13.)

The battery charging port is located on the right (with operator seated) housing of the machine.

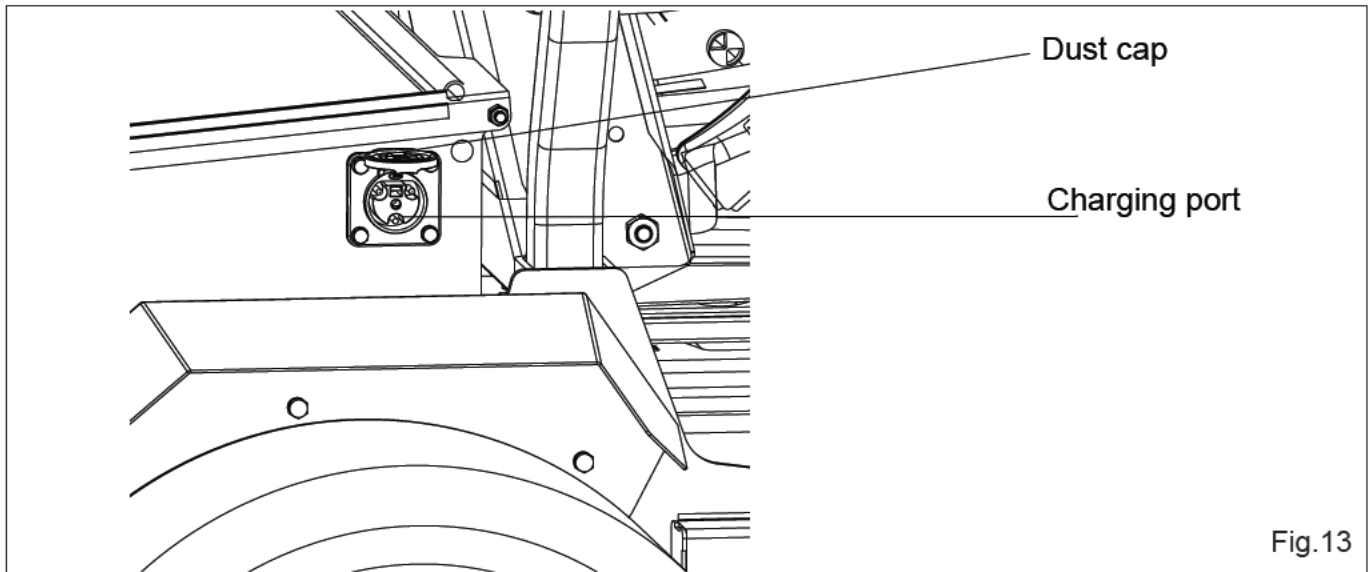

Battery charger

A Greenworks Commercial-approved battery charger is provided with the Greenworks Commercial Mower. There is also an individual charger manual. Save its instructions — this manual contains important safety and operating instructions for the battery charger provided with this machine. Do not attempt to charge batteries with a charger not designed for use with this product.

Battery Connectors

The battery connectors are located under the battery cover. Always disconnect battery cables by pulling inward on RED battery quick disconnect handle in battery box compartment before performing maintenance on the unit.

⚠ WARNING

DANGER! HIGH VOLTAGE!

Battery Charging

- Turn the ignition power switch to the “OFF” position, remove the key and make sure the machine comes to a complete stop.
- Remove the dust cap from the battery charging port on the mower and plug charger into the port.

NOTE: Plug will only fit one way into the port. Make sure it is properly aligned before inserting.

- Plug other end of charger into 100- to 120-volt household GFCI protected outlet that is rated at 15 amps or higher.

⚠ IMPORTANT

Never attempt to make any adjustments to the mower deck while the traction drive system is on or with the deck clutch engaged. Mower blades cannot be seen and are located very close to deck housing. Fingers and toes can be cut off instantly.

- Allow 10-12 hours for a full battery charge. Remove the charger from the charge port after 10 to 15 hours whether or not the green light comes on. Do not allow charger to charge more than 15 hours.
- Always turn charger “OFF” before disconnecting charger from mower. Disconnect charger cord from wall outlet.
- Cover the battery charging port with the dust cap and begin operating mower. More details of charger are referred to in the charger manual. Read and understand all its safety warnings and instructions. Failure to follow them may result in electrical shock, fire and/or serious injury.

ELECTRICAL SYSTEM

Charging Recommendations

⚠ WARNING

Do not smoke while servicing the batteries.

⚠ WARNING

Always wear safety glasses and protective clothing near battery. Use insulated tools.

- Lithium Modules do not develop a memory and need not be fully discharged before recharging.
- Batteries left uncharged will slowly discharge. Before initial use each spring season, be sure batteries have a full charge before mowing.
- If charger is not left plugged in, the batteries should be fully charged every 30 days to maintain battery life. Never allow charger to charge more than 15 hours.
- When charging, be sure charger cooling fan inlet and outlet are not blocked.

Disconnecting the Batteries (LITHIUM MODULES)

⚠ WARNING

Only Greenworks Commercial dealer or authorized service center can disconnect the battery.

⚠ WARNING

ALWAYS disconnect battery cables by pulling inward on RED battery quick disconnect handle in battery box compartment before ANY maintenance is performed on mower unit.

⚠ WARNING

Can only be operated by distributor!

- Open battery compartment and lift up battery cover to expose Lithium Modules
- Grasp RED BATTERY QUICK DISCONNECT HANDLE by wall of mower.
- Pull INWARD on lever until disengaged from wall plug.
- Unplug all red battery connectors by grasping each red plug and pull apart. DO NOT PULL ON BATTERY CABLES!! ONLY pull on connectors!!
- Battery may be removed (if needed) by lifting Lithium Module by silver handle on top of each battery case.

Reconnecting the Batteries (Lithium Modules)

⚠ WARNING

Only Greenworks Commercial dealer or authorized service center can connect the battery.

- Open battery compartment and lift up battery cover to expose Lithium Modules.
- Grasp RED BATTERY QUICK DISCONNECT LEVER.
- Push lever OUTWARD into battery compartment wall plug until "CLICK" is heard with complete connection. Take unused battery connector to plug into the next battery. Continue connecting batteries in a line until ALL batteries are connected to each other and ONLY one connector is left. The last unused connector can be used to plug into the internal charging port for charging the battery.
- Close battery compartment lid and turn lever to close.
- Mower is ready for use.

ELECTRICAL SYSTEM

DIGITAL DISPLAY

The function of the digital display (located on the control panel) is to provide electrical system information to the operator. It gives detailed information in the form of pattern, codes and number.

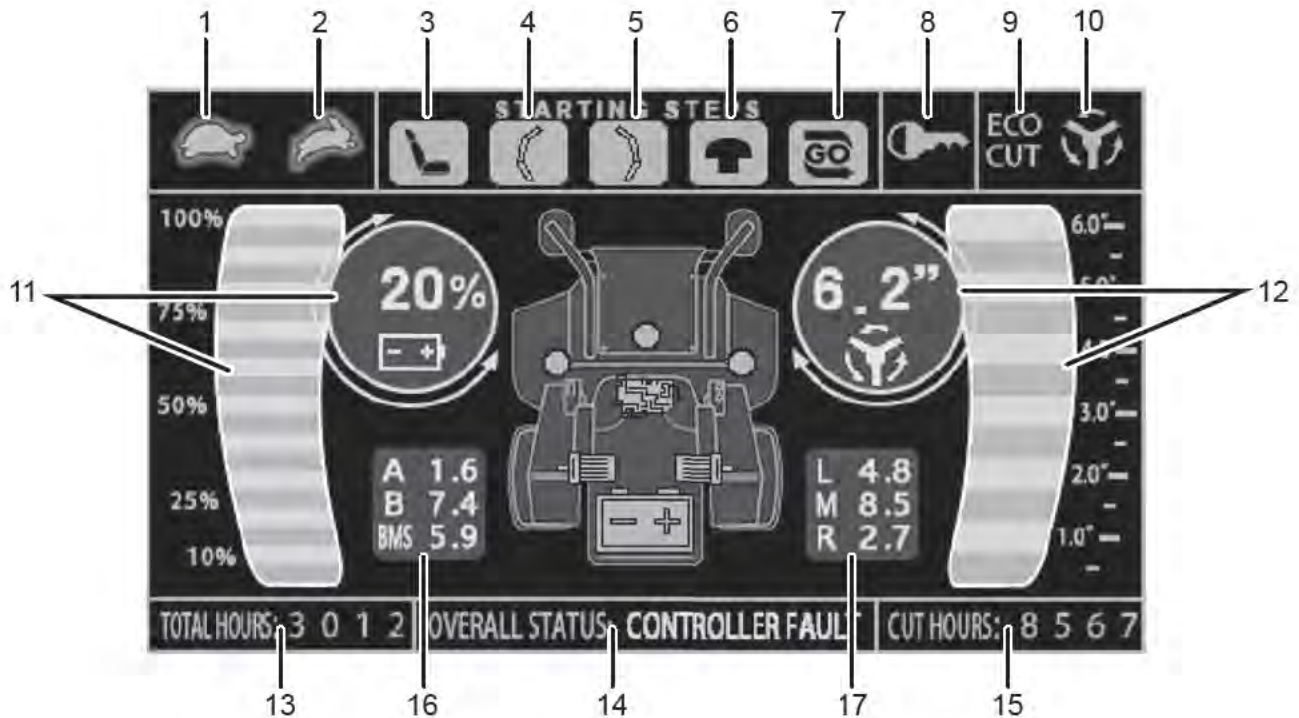

Know the digital display

No.	Icon	Meaning
1		low drive speed
2		high drive speed
3		seat switch
4		left control lever
5		right control lever
6		PTO switch
7		the whole machine is OK
8		need to restart
9		low blades speed
10		blade working
11		battery discharge indication
12		deck height indication
13	Drive hours	total working hours
14	Overall status	controller fault/ battery fault/ motor fault
15	Cutting hours	cutting hours

ELECTRICAL SYSTEM

15	L	left blade motor fault code
	A	master controller fault code
	BMS	battery fault code
17	R	right blade motor fault code
	B	slave controller
	M	middle blade motor fault code

FAULTS

The Canbus system will take action to protect the user and machine when it detects an issue. When it acts to turn off the machine or a component, it will indicate that a fault has occurred, and that fault will be shown on the digital display. All electrical faults have a letter code followed by a number.

The first letter describes the system that caused the fault according to this chart:

A	Master Controller
B	Slave Controller
BMS	Battery
R	Right Blade Motor
M	Middle Blade Motor
L	Left Blade Motor

Most faults are quickly corrected by noting what caused the issue, restarting the machine (cycle keyswitch/ignition [KSI]) and changing how the operator uses the machine. Use the below chart to find the solution for immediate fix during operation and a more detailed solution if the problem persists to be completed by a trained professional.

System	Code	Fault	Operator/Field Fix	Technical/Diagnostic Fix
A/B	1.2	Controller Overcurrent	If machine is operating under heavy load, reduce load with lower speed drive.	1. Inspect traction motor wires and connections as there may be a short. If there is, replace traction motor and wires.
			Cycle KSI	2. Replace controller
A/B	1.3	Current Sensor Fault	Cycle KSI	1. Inspect traction motor wires and connections as there may be a short. If there is, replace traction motor and wires.
				2. Replace controller
A/B	1.4	Precharge Failed	Cycle KSI	1. Check wire connections to keyswitch.
				2. Check the positive and negative poles of the mower controller are shorted
A/B	1.5	Controller Severe Undertemp	Bring unit into warm environment and allow the machine and battery to warm up.	Bring heatsink temperature above -40°C, and cycle interlock or KSI.
A/B	1.6	Controller Severe Overtemp	Stop vehicle and allow to cool down. If operating in a hot environment, wait until temperature cools down.	Bring heatsink temperature below +95°C, and cycle interlock or KSI.

ELECTRICAL SYSTEM

System	Code	Fault	Operator/Field Fix	Technical/Diagnostic Fix
A/B	1.7	Severe Under voltage	Check battery wires and connections; Check fuse state and main contact connections.	Capacitor bank voltage dropped below the Severe Undervoltage limit with FET bridge enabled.
A/B	1.8	Severe Overvoltage	Check battery wires and connections; Check fuse state and main contact connections.	Capacitor bank voltage exceeded the Severe Overvoltage limit with FET bridge enabled.
A/B	2.2	Controller Overtemp Cutback	Stop vehicle and allow to cool down. If operating in a hot environment, wait until temperature cools down.	Bring heatsink temperature below 85°C.
A/B	2.3	Under voltage Cutback	The battery voltage is too low Check battery wires and connections; Check fuse state and main contact connections.	<ol style="list-style-type: none"> 1. Normal operation. Fault shows that the batteries need recharging. Controller is performance limited at this voltage. 2. Battery parameters are misadjusted. 3. Non-controller system drain on battery. 4. Battery resistance too high. 5. Battery disconnected while driving. 6. See Monitor menu Battery: Capacitor Voltage. 7. Blown B+ fuse or main contactor did not close.
A/B	2.4	Overvoltage Cutback	Check battery wires and connections; Check fuse state and main contact connections.	<ol style="list-style-type: none"> 1. Normal operation. Fault shows that regen braking currents elevated the battery voltage during regen braking. Controller is performance limited at this voltage. 2. Battery parameters are misadjusted. 3. Battery resistance too high for given regen current. 4. Battery disconnected while regen braking. 5. See Monitor menu Battery: Capacitor Voltage.
A/B	2.5	(+5V) Supply Failure	External load impedance is too low.	<ol style="list-style-type: none"> 1. External load impedance on the +5V supply (pin 26) is too low. 2. See Monitor menu outputs:
A/B	2.6	Digital Out 6 Open/Short	External load impedance is too low.	<ol style="list-style-type: none"> 1. External load impedance on Digital Output 6 driver (pin19) is too low.
A/B	2.7	Digital Out 7 Open/Short	External load impedance is too low.	<ol style="list-style-type: none"> 1. External load impedance on Digital Output 7 driver (pin20) is too low.

ELECTRICAL SYSTEM

System	Code	Fault	Operator/Field Fix	Technical/Diagnostic Fix
A/B	2.8	Motor Temp Hot Cutback	Stop vehicle and allow to cool down. If operating in a hot environment, wait until temperature cools down.	<ol style="list-style-type: none"> 1. Motor temperature is at or above the programmed Temperature Hot setting, and the current is being cut back. 2. Motor Temperature Control Menu parameters are mis-tuned. 3. See Monitor menu » Motor: Temperature and » Inputs: Analog2. 4. If the application doesn't use a motor thermistor, Temp Compensation and Temp Cutback should be programmed Off.
A/B	2.9	Motor Temp Sensor Fault	Motor thermistor is not connected properly or motor temp sensor failure	<ol style="list-style-type: none"> 1. Motor thermistor is not connected properly. 2. If the application doesn't use a motor thermistor, Motor Temp Sensor Enable should be programmed Off. 3. See Monitor menu » Motor: Temperature and » Inputs: Analog2.
A/B	3.1	Main Open/Short	Open or short on driver load.	<ol style="list-style-type: none"> 1. Open or short on driver load.
A/B	3.2	Coil2 Driver Open/Short	Open or short on driver load.	<ol style="list-style-type: none"> 2. Dirty connector pins.
A/B	3.3	Coil3 Driver Open/Short	Open or short on driver load.	<ol style="list-style-type: none"> 3. Bad crimps or faulty wiring.
A/B	3.4	Coil4 Driver Open/Short	Open or short on driver load.	
A/B	3.5	PD Open/Short	Open or short on driver load.	
A/B	3.6	Encoder Fault	Motor encoder failure. Bad crimps or faulty wiring.	<ol style="list-style-type: none"> 1. Motor encoder failure. 2. Bad crimps or faulty wiring. 3. See Monitor menu » Motor: Motor RPM.
A/B	3.7	Motor Open	Check motor phase Bad crimps or faulty wiring.	<ol style="list-style-type: none"> 1. Motor phase is open. 2. Bad crimps or faulty wiring.
A/B	3.8	Main Contactor Welded	Main contactor failure	<ol style="list-style-type: none"> 1. Main contactor tips are welded closed. 2. Motor phase U or V is disconnected or open. 3. An alternate voltage path (such as an external precharge resistor) is providing a current to the capacitor bank (B+ connection terminal).
A/B	3.9	Main Contactor Did Not Close	Main contactor failure	<ol style="list-style-type: none"> 1. Main contactor did not close. 2. Main contactor tips are oxidized, burned, or not making good contact. 3. External load on capacitor bank (B+ connection terminal) that prevents capacitor bank from charging. 4. Blown B+ fuse.

ELECTRICAL SYSTEM

System	Code	Fault	Operator/Field Fix	Technical/Diagnostic Fix
A/B	4.1	Throttle Wiper High	Throttle failure	<ol style="list-style-type: none"> 1. See Monitor menu » Inputs: Throttle Pot. 2. Throttle pot wiper voltage too high. 3. Bring throttle pot wiper voltage below the fault threshold.
A/B	4.2	Throttle Wiper Low	Throttle failure	<ol style="list-style-type: none"> 1. See Monitor menu » Inputs: Throttle Pot. 2. Throttle pot wiper voltage too low. 3. Bring throttle pot wiper voltage above the fault threshold.
A/B	4.3	Pot2 Wiper High	Throttle failure	<ol style="list-style-type: none"> 1. See Monitor menu » Inputs: Pot2 Raw. 2. Pot2 wiper voltage too high. 3. Bring Pot2 wiper voltage below the fault threshold.
A/B	4.4	Pot2 Wiper Low	Throttle failure	<ol style="list-style-type: none"> 1. See Monitor menu » Inputs: Pot2 Raw. 2. Pot2 wiper voltage too low. 3. Bring Pot2 wiper voltage above the fault threshold.
A/B	4.5	Pot Low Overcurrent	Throttle failure	<ol style="list-style-type: none"> 1. See Monitor menu » Outputs: Pot Low. 2. Combined pot resistance connected to pot low is too low.
A/B	4.6	EEPROM Failure	Download the correct software (OS) and matching parameter default settings into the controller and cycle KSI.	Download the correct software (OS) and matching parameter default settings into the controller and cycle KSI.
A/B	4.7	HPD/Sequencing Fault	Reapply input s in correct sequence.	<ol style="list-style-type: none"> 1. KSI, interlock, direction, and throttle inputs applied in incorrect sequence. 2. Faulty wiring, crimps, or switches at KSI, interlock, direction, or throttle inputs. 3. See Monitor menu » Inputs.
A/B	4.7	Emer Rev HPD	Reapply input s in correct sequence.	At the conclusion of Emergency Reverse, the fault was set because various inputs were not returned to neutral. If EMR_Interlock = On, clear the interlock, throttle, and direction inputs. If EMR_Interlock = Off, clear the throttle and direction inputs.
A/B	4.9	Parameter Change Fault	Cycle KSI.	This is a safety fault caused by a change in certain parameter settings so that the vehicle will not operate until KSI is cycled.
A/B	5.2	Slave PDO Fault	Cycle KSI	Time between CAN PDO messages (between Master controller and Slave controller) received exceeded the PDO Timeout Period. Check the communication wires from slave controller.
A/B	5.3	Master or Slave HPD Fault	Reapply inputs in correct sequence.	<ol style="list-style-type: none"> 1. KSI, park switches ,PTO switch and throttle inputs applied in incorrect sequence. 2. Faulty wiring, crimps, or switches at KSI, park switches and throttle inputs.

ELECTRICAL SYSTEM

System	Code	Fault	Operator/Field Fix	Technical/Diagnostic Fix
A/B	5.4	Battery BMS Fault	Check the battery voltage , If battery is low, recharge; Restart vehicle; Replace battery and contact dealer	Check the battery voltage , If battery is low, recharge; Restart vehicle; Replace battery and contact dealer
A/B	5.5	BMS PDO Fault	Cycle KSI	Time between CAN PDO messages (between Master controller and BMS) received exceeded the PDO Timeout Period.Check the communcation wires from BMS
A/B	5.6	Seat State Fault	Make sure to sit in the seat before you can control the vehicle	Seat switch,PTO switch and throttle inputs applied in incorrect sequence.Reapply inputs in correct sequence.
A/B	5.8	Mower Communication Fault	Check mower controller communication connections; Replace mower controller .	Time between CAN PDO messages (between Master controller and Mowers) received exceeded the PDO Timeout Period. Check the communcation wires from mower controller
A/B	6.8	VCL Run Time Error	Edit VCL application software to fix this error condition; flash the new compiled software and matching parameter defaults; cycle KSI.	Edit VCL application software to fix this error condition; flash the new compiled software and matching parameter defaults; cycle KSI.
A/B	6.9	External Supply Out of Range	Bring the external supply current within range.	<ol style="list-style-type: none"> 1. External load on the 5V and 12V supplies draws either too much or too little current. 2. Fault Checking Menu parameters Ext Supply Max and Ext Supply Min are mis-tuned. 3. See Monitor menu » Outputs: Ext Supply Current.
A/B	7.1	OS General	Cycle KSI.	Cycle KSI.
A/B	7.2	PDO Timeout	Cycle KSI or receive CAN NMT message.	Cycle KSI or receive CAN NMT message.
A/B	7.3	Stall Detected	Stalled motor. Motor encoder failure	Either cycle KSI, or detect valid motor encoder s ignals while oper at ing in LOS mode and return Throttle Command = 0 and Motor RPM = 0.
A/B	7.7	Supervisor Fault	Check for noise or voltage drift in all switch inputs; check connections; cycle KSI.	Check for noise or voltage drift in all switch inputs; check connections;cycle KSI.
A/B	7.8	Supervisor Incompatible	Load properly matched OS code or update the Supervisor code; cycle KSI.	Load properly matched OS code or update the Supervisor code; cycle KSI.
A/B	8.7	Motor Characterization Fault	Correct fault; cycle KSI.	Correct fault; cycle KSI.

ELECTRICAL SYSTEM

System	Code	Fault	Operator/Field Fix	Technical/Diagnostic Fix
A/B	8.8	Encoder Pulse Error	Ensure the Encoder Steps parameter matches the actual encoder; cycle KSI.	Ensure the Encoder Steps parameter matches the actual encoder; cycle KSI.
A/B	8.9	Motor Type Fault	Set Motor_Type to correct value and cycle KSI.	Set Motor_Type to correct value and cycle KSI.
A/B	9.1	VCL/OS Mismatch	Download the correct VCL and OS software into the controller.	Download the correct VCL and OS software into the controller.
A/B	9.2	EM Brake Failed to Set	Activate the throttle.	Activate the throttle.
A/B	9.3	Encoder LOS (Limited Operating Strategy)	Cycle KSI or, if LOS mode was activated by the Stall Fault, clear by ensuring encoder senses proper operation, Motor RPM = 0, and Throttle Command = 0.	Cycle KSI or, if LOS mode was activated by the Stall Fault, clear by ensuring encoder senses proper operation, Motor RPM = 0, and Throttle Command = 0.
A/B	9.4	EMR Rev Timeout	Turn the emergency reverse input Off.	Turn the emergency reverse input Off.
A/B	9.8	Illegal Model Number	Download appropriate software for your controller model.	Download appropriate software for your controller model.
BMS	X.X	Battery BMS Fault	Check the battery voltage , If battery is low, recharge; Restart vehicle.	Check the battery voltage. If battery is low, recharge; Restart vehicle once properly charged.
R/M/L	1.2	UNDER-VOLTAGE CUTBACK	The battery voltage is too low Check battery wires and connections; Check fuse state and main contact connections.	<ol style="list-style-type: none"> 1. Normal operation. Fault shows that the batteries need recharging. Controller is performance limited at this voltage. 2. Battery parameters are misadjusted. 3. Non-controller system drain on battery. 4. Battery resistance too high. 5. Battery disconnected while driving.
R/M/L	1.3	OVERVOLTAGE CUTBACK	Check battery wires and connections; Check fuse state and main contact connections.	<ol style="list-style-type: none"> 1. Normal operation. Fault shows that regen braking currents elevated the battery voltage during regen braking. Controller is performance limited at this voltage. 2. Battery parameters are misadjusted. 3. Battery resistance too high for given regen current. 4. Battery disconnected while regen braking.
R/M/L	1.4	CONTROLLER SEVERE OVERTEMP	If machine is operating under heavy load, reduce load with lower speed blade until temperature cools down.	Bring heatsink temperature below +85°C, and cycle interlock or KSI.

ELECTRICAL SYSTEM

System	Code	Fault	Operator/Field Fix	Technical/Diagnostic Fix
R/M/L	1.5	MOTOR TEMP HOT CUTBACK	If machine is operating under heavy load, reduce load with lower speed blade until temperature cools down.	<ol style="list-style-type: none"> 1. Motor temperature is at or above the programmed Temperature Hot setting, and the current is being cut back. 2. Motor Temperature Control Menu parameters are mis-tuned. 3. If the application doesn't use a motor thermistor, Temp Compensation and Temp Cutback should be programmed Off.
R/M/L	2.1	THROTTLE	Throttle failure	<ol style="list-style-type: none"> 1. Throttle pot wiper voltage too high. 2. Bring throttle pot wiper voltage below the fault threshold. 3. Throttle type may be error
R/M/L	2.1	HPD SEQUENCING	Reapply inputs in correct sequence.	Reapply inputs in correct sequence.
R/M/L	2.2	MAIN CONTACTOR DID NOT CLOSE	Main contactor failure	<ol style="list-style-type: none"> 1. Main contactor did not close. 2. Main contactor tips are oxidized, burned, or not making good contact. 3. External load on capacitor bank (B+ connection terminal) that prevents capacitor bank from charging. 4. Blown B+ fuse.
R/M/L	2.2	PRECHARGE FAILED	Cycle KSI	<ol style="list-style-type: none"> 1. Check wire connections to keyswitch. 2. Check the positive and negative poles of the mower controller are shorted.
R/M/L	2.3	STALL DETECTED	Stalled motor. Motor encoder failure	<ol style="list-style-type: none"> 1. Stalled motor. 2. Motor encoder failure. 3. Bad crimps or faulty wiring. 4. Problems with power supply for the motor encoder.
R/M/L	2.4	MOTOR OPEN	Check motor phase Bad crimps or faulty wiring.	<ol style="list-style-type: none"> 1. Motor phase is open. 2. Bad crimps or faulty wiring.
R/M/L	2.5	EMBRAKE DRIVER FAULT	Electromagnetic brake driver is either open or shorted. Cycle KSI	<ol style="list-style-type: none"> 1. Electromagnetic brake driver is either open or shorted. 2. Cycle KSI
R/M/L	3.1	EM BRAKE FAILED TO SET	After the EM Brake was commanded to set and time has elapsed to allow the brake to fully engage, vehicle movement has been sensed.	After the EM Brake was commanded to set and time has elapsed to allow the brake to fully engage, vehicle movement has been sensed.
R/M/L	3.1	EMER REV TIMEOUT	Emergency Reverse was activated and ran until the EMR Timeout timer expired.	Emergency Reverse was activated and ran until the EMR Timeout timer expired.
R/M/L	3.2	EMR SRO	The EMR switches are turned on before KSI	The EMR switches are turned on before KSI

ELECTRICAL SYSTEM

System	Code	Fault	Operator/Field Fix	Technical/Diagnostic Fix
R/M/L	3.3	PUMP DRIVER FAULT	Pump driver is either open or shorted	Pump driver is either open or shorted
R/M/L	3.4	PUMP SRO	The lift switch is turned on before KSI	The lift switch is turned on before KSI
R/M/L	3.5	VALVE DRIVER FAULT	Valve driver is either open or shorted	Valve driver is either open or shorted
R/M/L	3.6	VALVE SRO	The lower valve input switches are turned on before KSI	The lower valve input switches are turned on before KSI
R/M/L	4.1	EXTERNAL SUPPLY OUT OF RANGE	The voltage of external +5V or +14V is either greater than the upper voltage threshold or lower than the lower voltage threshold.	The voltage of external +5V or +14V is either greater than the upper voltage threshold or lower than the lower voltage threshold.
R/M/L	4.2	CAN BUS LOADING	Check mower controller communication connections; Cycle KSI	Check mower controller communication connections; Replace mower controller .
R/M/L	4.2	PDO MAPPING ERROR	Cycle KSI	Check mower controller communication connections; Check the parameter of the CAN Interface; Cycle KSI
R/M/L	4.3	HW FAILSAVE	Cycle KSI	The hardware is defeated
R/M/L	4.4	SW FAULT	Cycle KSI	The CRC code of the application is not right
R/M/L	8.1	PARAMETER CHANGE	Cycle KSI	Adjustment of a parameter that requires cycling of KSI
R/M/L	8.3	NV FAILURE	Cycle KSI	Controller operating system tried to write to EEPROM memory and failed.
R/M/L	8.4	SUPERVISION	Cycle KSI	Mismatched redundant readings; damaged Supervisor

MAINTENANCE

REGULAR MAINTENANCE

Regular maintenance is the best prevention for costly downtime or expensive, premature repair. The following pages contain suggested maintenance information and schedules which the operator should follow on a routine basis. For more detailed information, order the correct parts manual for your unit. Remain alert for unusual noises, as they could be signaling a problem. Visually inspect the machine for any abnormal wear or damage. A good time to detect potential problems is while performing scheduled maintenance service. Correcting the problem as quickly as possible is the best insurance. Inspect mower daily for grass clippings, along with wire and string tangles. The underside of the mower deck may collect a buildup of grass clippings and dirt, especially when grass is wet or has high moisture content. This build-up will harden, restricting blade and air movement and will probably result in a poorer quality of cut; therefore, it should be removed routinely. To do this, it will be necessary to raise and block the deck, using jack stands or blocks, in the full up position and scrape the build-up from underneath.

TIRES

It is important for level mowing that all tires have the correct amount of air pressure. The recommended pressure are:

Drive wheels	20 psi
Front caster wheels	20 psi

NOTE: Inspect the tires daily. Replace immediately if it is damaged.

LUBRICATION

Use SAE multi-purpose grease.

MOWER BLADE MAINTENANCE

Check the mower blades daily. They are the key to power efficiency and well-groomed turf. Keep them sharp -- a dull blade will tear rather than cut the grass, leaving a brown ragged top on the grass within a few hours. A dull blade also requires more power. Replace any blade that is bent, cracked or broken.

⚠ WARNING

Never attempt to straighten a bent blade by heating, or weld a cracked or broken blade as the blade may break and cause serious injury. Replace worn or damaged blades.

⚠ WARNING

Never work with blades while key is in the ignition switch. Turn key to "OFF" position, remove key from switch and disconnect battery cables by pulling inward on RED battery quick disconnect handle in battery box compartment. Block up mower when you must work under it. Wear gloves when handling blades. Always check for blade damage if mower strikes a rock, branch or other foreign objects!

⚠ WARNING

Always wear adequate eye protection when grinding mower blades.

Mower blade removal

- Turn key to "OFF" position, remove key from switch and disconnect battery cables by pulling inward on RED battery quick disconnect handle in battery box compartment.
- Lift the front of the mower and block and secure the machine to allow serviceman to change the blade under the mower.
- While wearing leather padded gloves, grasp the blade closely with one hand in order to prevent the blade from turning and use a 24mm wrench with your other hand to loosen the bolt fixing its blade in place.
- Turn the bolt COUNTERCLOCKWISE to loosen and CLOCKWISE to tighten.
- Remove the bolt and the blade.
- To re-install the new blade, position the blade with the cutting edges toward the ground. Assemble the bolt. Using a socket or wrench, turn the blade nut CLOCKWISE in order to secure the blade.

MAINTENANCE

TORQUE VALUES

⚠ WARNING

Particular attention must be given to tightening the drive wheel lug nuts and blade spindle bolts. Failure to correctly torque these items may result in the loss of a wheel or blade, which can cause serious damage or personal injury.

Torque values are given below:

Part	Ft-lbs.	Nm
Wheel (lug) nuts	103-118	140-160
Blade spindle bolt bottom	114-118	155-160

Lug nuts only - It is recommended that these be checked after the first 2 hours of operation, initially, every 100 hours and following removal for repair or replacement.

For all other torques refer to the various mower parts manuals for standard torque chart.

NOTE: The blade adapter will come off when the blade cap screw is removed. Touch-up sharpening can be done with a file. Check the blades for balance following grinding. A commercial balancing tool is available through most hardware supply stores, or balancing can be done by placing the blade on an inverted line punch or 1/2" bolt. Blade should not lean or tilt. While spinning the blade slowly, it should not wobble. If blade is out of balance, true it up before reinstalling. Lay the blade on a flat surface and check for distortion. Replace any distorted blade.

⚠ WARNING

The blade sail (curved part) must be pointing upward toward the inside of the deck to ensure proper cutting.

⚠ WARNING

When mounting blades, rotate them after installation to ensure blade tips do not touch each other or sides of the mower.

⚠ WARNING

Failure to correctly torque the bolt may result in the loss of the blade, which can cause serious injury.

⚠ WARNING

Mower blades are sharp and can cut. Wear gloves and use extra caution when servicing them.

SEAT BELT MAINTENANCE

Inspect the seat belt system (all seat, seat belt parts, seat pan and seat pan latch) daily prior to mowing for signs of any damage. These parts should be replaced if any parts indicate signs of:

- A. cuts
- B. fraying
- C. extreme or unusual wear
- D. significant discoloration due to UV exposure
- E. dirt or stiffness
- F. abrasion to the seat belt webbing
- G. damage to the buckle, latch plate or hardware.
- H. any other problem

If the seat belt is to be cleaned, use soap and water. Do not use carbon tetrachloride, naphtha, etc., as these will weaken the webbing. For the same reason, do not bleach or dye the webbing. Replace seat belt if worn or damaged.

MAINTENANCE

ROPS MAINTENANCE

ROPS Inspection

NOTE: Inspect the ROPS after the first 20 hours of operation.

- Check the torque of the ROPS mounting bolts. Tighten the bolts to the correct torques as shown below if necessary.
- Inspect the operator's seat and the mounting parts for the seat belt. Tighten the bolts to the correct torque as shown below, if necessary, and replace parts that show wear or damage.
- Inspect the seat latch to make sure it is secured and functioning properly. Adjust or repair, as necessary.

⚠ WARNING

Make sure seat pan is securely bolted down prior to each use to prevent seat from moving/ tilting in the event of mower tipping or rolling over.

Possible damage to the ROPS

If the unit has rolled over or the ROPS has been in some other type of accident (such as hitting an overhead object during transport), the ROPS must be replaced to retain the best protection. Following an accident, check the ROPS, the operator's seat, the seat belt, seat belt mountings and seat latch for possible damage. Before operating the machine, replace all damaged parts.

⚠ WARNING

The ROPS structure's protective capability may be impaired by structural damage, overturn or alteration. Do not remove or alter any of the ROPS parts. Do not attempt to weld or straighten ROPS. Failure to adhere to these instructions could result in severe injury or death.

CLEANING THE MOWER

⚠ WARNING

In order to reduce the risk of electric shock, do not expose the mower to water. The underside of the mower deck should be cleaned after each use because grass clippings, leaves, dirt, and other debris will accumulate, which will cause rust and corrosion.

Remove any build-up of grass and leaves on or around the motor cover (do not use water). Occasionally wipe the mower clean with a dry cloth. If debris builds up on the underside of the mower during use, stop the motor, turn off the machine, and scrape it clean using an appropriate tool.

STORING THE MOWER

The following steps should be taken in order to prepare the lawn mower for storage.

- Clean the mower as described in the previous section.
- Inspect the blade and replace it or sharpen it, if required (refer to the Maintenance section).
- Store the mower in a dry, clean location. Do not store it next to corrosive materials, such as fertilizer or rock salt.
- Store the mower indoors, in a cool, dry place, out of the reach of children. Do not cover the lawn mower with a solid plastic sheet. Plastic coverings trap moisture around the mower, which causes rust and corrosion.
- Check thoroughly for any worn or damaged parts that need replacing and order them from your dealer.
- Thoroughly lubricate machine, according to lubrication instructions.
- Fully charge and service the batteries.
- Do not deflate tires.

MAINTENANCE

- The mower should be stored in a well-ventilated, clean and dry place as the battery charger cannot be used in a wet environment. Connect the battery charger to the charger port.
 - Always keep the batteries fully charged. It is especially important to prevent battery damage when the temperature is below 32°F (0°C).
 - Attach the charger adapter to the charging port and the batteries per the Charging Adapter section in the Electrical System section.
 - Plug the charger into a proper electrical outlet. Refer to Battery Charger, Battery Charging and Charging Recommendations portions of the Electrical System section for more details on using the charger and charging the batteries.
 - For additional information on battery storage, refer to the Battery Storage portion of the Electrical System section of this manual.
 - To maximize battery life it is best to fully charge batteries shortly after each use.

GET A HEADSTART ON PREPARATION

Before starting the mower following storage, the following servicing is required:

- Clean machine, removing trash and dirt.
- Tighten any loose bolts and make sure all hair pins, cotter pins and clevis pins are in place.
- Install all safety shields and covers and review safety precautions listed in this manual.
- Check and inflate tires to 20 PSI.
- Attach the tractor harness to the charging port and the batteries per the Charging Adapter portion in the Electrical System section.
- Close seat pan and re-install seat pan hardware.

⚠ WARNING

Make sure seat pan is securely bolted down prior to each use to prevent seat from moving/tilting in the event of mower tipping or rollover.

BATTERY MAINTENANCE

⚠ WARNING

When servicing, use only identical Greenworks replacement parts. Use of any other parts may create a hazard or cause product damage.

⚠ WARNING

It is not recommended to use compressed dry air as cleaning method of the charger. If cleaning with compressed air is the only method available, always wear safety goggles or safety glasses with side shields. If the environment is dusty, also wear a dust mask.

Your Greenworks Commercial mower is powered by a lithium module which, when maintained properly, will provide years of useful life. For proper care, adhere to the following instructions:

- Always charge batteries after each use, regardless of how little used. Batteries must be attached to a plugged-in battery charger with the charger power switch "ON" when the unit is not being used.
-

⚠ WARNING

Charge only with a Greenworks Commercial approved charger. Do not use battery chargers other than those recommended by Greenworks Commercial Equipment. Incorrect battery charging will void warranty and can lead to equipment damage, serious injury or death.

- Check that battery cables are securely tightened to batteries each time you service the battery.
- Keep grass, dirt and debris from collecting near battery terminals.
- Batteries are not to remain in a discharged state or damage to the batteries will occur.
- Charge batteries indoors in a well-ventilated and dry location away from sparks or flames. Never expose charger to rain, vapor or liquid.

MAINTENANCE

- Charge only lithium batteries provided by Greenworks Commercial.
- Do not touch uninsulated portion of charger (terminal pins) or of output connector.
- Do not use with defective cords and wires. Replace defective cords and wires immediately.

Lithium energy module maintenance

In order to prolong the battery module life cycle and make sure the module stays in good condition, please adhere to the following instructions.

1. Whenever a battery pack is fully discharged and turned off, DO NOT USE IT AGAIN until it is recharged. Over-discharge of the battery pack means the battery life will be shortened and the battery may become permanently damaged.
2. Whenever a battery pack is fully discharged and turned off. It is best to recharge the battery as soon as possible. There is no need to fully charge; it will be beneficial even if you only charge the module for 5-10 minutes. It is best to recharge it within 24 hours.
3. For the charging, charge every module separately as often as possible. Certain module pairs (MODULE A and MODULE B) can be charged in parallel (while linked together), but, each module should be charged separate at least every 20-30 charging cycles, or when total run time is reduced.
4. Before connecting in parallel, please make sure the modules have the same SOC (State of Charge, or Voltage). Different SOC means different voltage and may charge/discharge to each other.
5. If the battery module will not be used for a long time (several days or weeks), please disconnect the connectors between modules and loads.
6. For long-term storage, please keep the SOC at around 50% of the battery pack's fully charged voltage level. To reach that point, you can fully discharge the battery pack and then recharge the pack in half the charging time.
7. For long-term storage, please discharge and recharge the pack in half the charging time.
8. For long-term storage, please make sure the storage temperature is -4oF - 113oF within one month, and 32oF - 95oF between two and 12 months.
9. The best working environment of the battery module is 5°F - 113°F. Battery modules can be used a -4°F - 131°F for discharge, and 32°F - 107°F for charge.
10. Avoid severe vibration. Do not throw or drop the battery pack.

SERVICE

- Park the mower on level ground. Make sure that steering control levers are in the neutral position, and that the deck blade switch is in "OFF" position. Raise deck, rotate key to "OFF" position, remove key from switch and disconnect battery cables by pulling inward on RED battery quick disconnect handle in battery box compartment.

⚠ I M P O R T A N T

Wait for all movement to stop before adjusting, cleaning or repairing. Repairs or maintenance requiring power should be performed by trained maintenance personnel only. Read and observe safety warnings in front of manual.

- Any maintenance operation that requires the removal of safety covers must be performed by a trained service technician.
- Before working on or under the deck, make certain master power ignition switch is "OFF" and key is removed and deck blade switch cannot be accidentally started and disconnect battery cables by pulling inward on RED battery quick disconnect handle in battery box compartment.

⚠ I M P O R T A N T

Repairs or maintenance requiring power should be performed by trained maintenance personnel only.

- Use a stick or similar instrument to clean under the mower, making sure that no part of the body -- especially arms and hands -- is under mower.
- Keep your machine clean and remove any deposits of trash and clippings. These can cause fires and overheating. Allow machine to cool before storing.

MAINTENANCE

- Prevent fires by keeping battery compartment, deck and operator's station clean of accumulated trash, grass clippings, and other debris.
- Clean battery compartment, drive motor compartment, mower deck, seat, etc., of all dirt and debris. To clean, use only compressed air. DO NOT use water, solvents, hard cleaners or abrasives.
- Always wear adequate eye protection when servicing the batteries or when grinding mower blades and removing accumulated debris. Never attempt to make any adjustments or repairs to the mower's drive system, mower deck or any attachment while the traction drive system is running. Repairs or maintenance requiring power should be performed by trained maintenance personnel only.
- Never work under the machine or attachment unless it is safely supported with jack stands. Make certain machine is secure when it is raised and placed on the jack stands.
- The jack stands should not allow the machine to move when the traction drive system is running and the drive wheels are rotating. Use only certified jack stands. Use only appropriate jack stands, with a minimum weight rating of 2000 pounds (907.2 kg) to block the unit up. Use in pairs only. Follow the instructions supplied with the vehicle stands.
- Do not touch hot parts of machine.
- Keep nuts and bolts tight, especially the blade attachment bolts. Keep equipment in good working condition.
- Never tamper with safety devices. Check their proper operation regularly.
- Turn the key to the "OFF" position before unclogging the discharge chute.
- Never clear the discharge chute with the machine running. Turn the key to the "OFF" position and be sure the blades have stopped before cleaning. Use a stick to clear a plugged discharge area. Never use your hand!
- Stop unit and allow blades to stop before unclogging chute. Grass collection system components are subject to wear, damage and deterioration, which could expose moving parts or allow objects to be thrown. Frequently check components and replace with manufacturer's recommended parts, when necessary.
- Exercise caution when working under the deck as the mower blades are extremely sharp. Wear gloves and use extra caution when servicing them.
- Use only genuine Greenworks Commercial Mower parts to ensure that original standards are maintained.
- Always disconnect batteries when transporting unit. Keep unit free of grass clippings, leaves and other debris.

ENVIRONMENTALLY SAFE BATTERY DISPOSAL

The following toxic and corrosive materials are in the batteries used in this lawnmower: lithium-ion.



⚠ WARNING

All toxic materials must be disposed of in a specified manner to prevent contamination of the environment. Before disposing of damaged or worn-out lithium-ion battery packs, contact your local waste disposal agency, or the local Environmental Protection Agency office for information and specific instructions. Take the batteries to a local recycling and/or disposal center certified for lithium-ion disposal.

⚠ WARNING





If the battery pack cracks or breaks, with or without leaks, do not recharge or use the battery. Dispose of it and replace with a new battery pack. **DO NOT ATTEMPT TO REPAIR IT!** To avoid injury and risk of explosion or electric shock, and to avoid damage to the environment, cover the battery's terminals with heavy-duty adhesive tape.

- DO NOT attempt to remove or destroy any of the battery pack components.
 - DO NOT attempt to open the battery pack.
 - If a leak develops, the released electrolytes are corrosive and toxic. DO NOT get the solution in the eyes or on skin, and do not swallow it.
 - DO NOT place these batteries in your regular household trash.
 - DO NOT incinerate.
 - DO NOT place them where they will become part of any waste landfill or municipal solid waste stream.
-

TROUBLESHOOTING

PROBLEM	POSSIBLE CAUSE	SOLUTION
If error pattern are showing on the digital display	Numerous.	Refer to Digital display in the section of this manual.
		Contact your Greenworks Commercial dealer.
There is abnormal vibration	The cutting blade(s) is/ are bent or unbalanced.	Install new cutting blade(s).
	A blade mounting bolt is loose.	Tighten the blade mounting bolt.
	Numerous.	Contact your Greenworks Commercial dealer.
Uneven cutting height	The blade(s) are not sharp.	Sharpen the blades.
	A cutting blade(s) is/are bent.	Install new cutting blade(s).
	The deck is not level.	Level the deck per the Deck leveling and height adjustment section of the parts manual.
	An anti-scalp wheel is not set correctly.	Adjust the height of the anti-scalp wheel.
	The underside of the deck is dirty.	Clean the underside of the deck.
	Tires improperly inflated.	Adjust air pressure and ensure even pressure between tines.
	A blade spindle is bent.	Contact your Greenworks Commercial dealer.
Loss of deck operation	If deck control does not provide image to the Digital Display and the deck fails to operate with fully charged batteries.	Contact your Greenworks Commercial dealer.
Mower will not start	Switch key is in the "OFF" position.	Check that key is in the "ON" position.
	Battery is not charged.	Check all battery connections in back battery compartment. Make sure batteries are charged.
	Circuit breakers are tripped.	Check to see that ALL circuit breakers are not tripped.

TROUBLESHOOTING

Deck System Resistance Test Procedure	
	Make sure your Digital Multimeter is capable of measuring up to 1.2 million ohms(Ω) resistance before beginning these steps. Refer to your Digital Multimeter Owner's Manual for correct dial settings.
	Always disconnect the batteries before performing any maintenance or repair.
	Wait 5 minutes after disconnecting the batteries before working on the machine.
1	Remove any debris build-up from all deck components.
2	Verify all power connections on deck motors and deck controller are torqued properly. If loose connections are discovered, tighten to the correct torque values found in service and repair manual. Reconnect the batteries per the instructions in the service and repair manual and check for proper deck operation. If loose connections are not found, proceed to step 3.
	3 Label all (8) deck controller connection points (per Figure 3, page 13) on the edge of the deck controller housing so they are easily viewed for correct re-connections.
	4 To ensure correct re-connection, mark all (8) wire connections with the corresponding connection point labels from step 3.
5	Remove all (8) wire connections from the deck controller.
6	Measure deck controller resistance (Ω) : Reference Figure 3, page 13. (A) Place the negative (-) probe of a digital multimeter on the positive (+) battery terminal of the deck controller. (B) Place the positive (+) probe of the digital multimeter on deck controller terminals AR, then CR. Resistance for each should read between 270K (Ω) and 330k (Ω). If resistance is above or below the specified range, the deck controller will need to be replaced. Repeat process for deck controller terminals AL, BL and CL.
7	If no issues are found, reinstall deck controller wire connections to the proper torque values located in the service and repair manual. (See page 28)
8	Measure deck motor resistance (Ω): Reference Figure 4, page 13. (A) Place the negative (-) probe of a digital multimeter on motor terminal A. (B) Place the positive (+) probe of the digital multimeter on motor terminals B, then C. If the resistance is more than 0 to 1 (Ω) ohms the deck motor will need to be replaced. Repeat process for other deck motor as needed.
9	Measure the resistance in the six-pin motor connector (per Figure 5, page 13) by placing the negative (-) probe of a digital multimeter on pin 2 and the positive (+) probe on pin 3. Resistance should read between 800k(Ω) and 1.2m (Ω) ohms. Resistance between pin 2 and pins 1,4,5 and 6 should be 0 ohms. If resistances are above or below these ranges, the deck motor will need to be replaced. Repeat the process for the other motor as needed.
10	If steps 1-9 are completed and the issues persist, please refer to the mower manufacturer's procedure for wiring harness troubleshooting for possible repair or replacement.

LIMITED WARRANTY

WHAT IS COVERED BY THIS WARRANTY

Greenworks Commercial Products makes the following warranty to the original purchaser only:

A. Residential Use: Greenworks Commercial Mowers used for normal residential purposes* are warranted for two (2) years or 150 hours total usage (whichever comes first) from date of delivery on all materials and workmanship. If the Purchaser discovers within this warranty period (two years from date of delivery) a defect in materials or workmanship:

- He must promptly notify Greenworks Commercial or an authorized dealer, in writing, of the defect. In no event shall such notification be received by Greenworks Commercial, or an authorized dealer later than twenty-four (24) months from date of delivery.
- Within a reasonable time after such notification, Greenworks Commercial will correct any defect in material or workmanship on the Greenworks Commercial Mower by repairing or replacing part(s) with either new or used replacement parts.
- Such repair, including parts and labor, shall be at the expense of Greenworks Commercial, and the batteries are covered by a three (3) year limited warranty or 500-hour usage, whichever comes first to the original owner (consumer) only.

Note: Failure to properly maintain batteries and keep them fully charged will reduce battery life and will void battery warranty. The provisions of this limited warranty shall not apply to failure due to:

- *abuse or neglect such as improper fluid levels, water damage, loose wiring, or rusted or corroded hardware.*
- *lack of proper maintenance; damage caused by improper installation of the battery; neglect, breakage, freezing, fire, explosion, wreckage, the addition of any chemical, operation of the battery in an overcharged, or the operation of the battery in an uncharged condition.*
- *a battery charged by systems other than the original equipment type battery charger.*

Note: "Normal residential purposes" means use of product on same lot as your home. Use at more than one location is considered commercial use, and then the commercial use warranty would apply.

B. Commercial Use: Greenworks Commercial Mowers used for commercial and institutional use are warranted for two(2) years or 500 hours total usage (whichever comes first) from date of delivery on all materials and workmanship of chassis and deck structures and one (1) year or 500 hours total usage (whichever comes first) from date of delivery on all materials and workmanship. If the purchaser discovers within this warranty period a defect in materials or workmanship, he must promptly notify Greenworks Commercial Products, or an authorized dealer, in writing, of the defect. In no event shall such notification be received by Greenworks Commercial, or an authorized dealer later than 12-24 months from date of delivery.

Within a reasonable time after such notification, Greenworks Commercial Products will correct any defect in material or workmanship on the Greenworks Commercial Mower, by repairing or replacing part(s) with either new or used replacement parts. Such repair, including parts and labor, shall be at the expense of Greenworks Commercial Products, and, the batteries are covered by a three (3) year limited warranty, or 500 hr. usage, whichever comes first to the original owner (commercial) only.

Note: Failure to properly maintain batteries and keep them fully charged will reduce battery life and will void battery warranty. The provisions of this limited warranty shall not apply to failure due to:

- *abuse or neglect such as water damage, loose wiring, or rusted or corroded hardware;*
- *abuse or neglect such as water damage, loose wiring, or rusted or corroded hardware;*
- *lack of proper maintenance; damage caused by improper installation of the battery; neglect, breakage, freezing, fire, explosion, wreckage, the addition of any chemical, operation of the battery in an overcharged, or the operation of the battery in an uncharged condition;*
- *a battery charged by systems other than the original equipment type battery charger.*

LIMITED WARRANTY

C. Rental Use: Greenworks Commercial Mowers used in rental applications are not covered by warranty. This also includes no warranty on the batteries.

WHO MUST PERFORM THE WARRANTY SERVICE

All warranty service will be performed by dealers authorized by Greenworks Commercial. Service calls and/or transportation expense of the product to and from the authorized dealer, for warranty work, will be paid by the owner of the product. For warranty service, contact an authorized dealer.

WHAT IS NOT COVERED BY THIS WARRANTY

Greenworks Commercial does not warranty:

- Some products, components or parts not manufactured by Greenworks Commercial.
- Repairs made by unauthorized persons.
- Damage caused by use of the Greenworks Commercial Mower for purposes other than those for which it was designed.
- Damages caused by disasters such as fire, flood, wind, and lightening.
- Damages caused by neglect, abuse, abnormal use, improper or unreasonable use, accident, negligence or misuse such as water damage.
- Repairs or replacement resulting from the use of unauthorized parts, accessories or attachments.
- Repairs or replacement as the result if any alterations or modifications, in the determination of Greenworks Commercial, which adversely affects the operation, performance or durability of the equipment.
- Mowers that have had their serial number removed or made illegible.
- Depreciation or damage caused by normal wear, lack of reasonable and proper maintenance, failure to follow the product's owner's manual operating, maintenance and adjustment instructions or other operational instructions provided by Greenworks Commercial.
- Normal maintenance parts and service including, but not limited to, lubricants, tune-up parts, blades, blade sharpening, bearings, brake or steering adjustments.

DISCLAIMER OF WARRANTY

The foregoing warranties are in lieu of all other warranties, expressed or implied, including but not limited to the implied warranties of merchantability and fitness for a particular purpose. However, if the Greenworks Mower is purchased as a consumer product, any implied warranty of merchantability or fitness for a particular purpose is limited to the duration of this limited warranty. Some states do not allow limitations on how long an implied warranty lasts, so the above limitation may not apply to you. This warranty gives you specific legal rights, and you may also have other rights which vary from state to state.

LIMITATION OF REMEDIES

In no case shall Greenworks Commercial be liable for any special, incidental, or consequential damages based upon breach of warranty, breach of contract, negligence, strict liability in tort, or any other legal theory. Such damages include, but are not limited to:

- Loss of profits
- Loss of savings or revenue
- Loss of use of the Greenworks Commercial Mower or any associated equipment
- Cost of capital
- Cost of any substitute equipment, facilities, services or downtime
- The claims of third parties, including customers, and injury to property

TIME LIMIT

Any action for breach of warranty must be commenced within 24 months following delivery of the goods in a residential application. Any action for breach of warranty must be commenced within twelve to 12-24 months following delivery of the goods in a commercial application.

LIMITED WARRANTY

NO OTHER WARRANTIES

This agreement is understood to be the complete and exclusive agreement between the parties, superseding all prior agreements, oral or written, and all other communications between the parties relating to the subject matter of this agreement.

ALLOCATION OF RISKS

This agreement allocates the risks of product failure between Greenworks Commercial and the purchaser. This allocation is recognized by both parties and is reflected in the price of the goods.

OWNER'S RESPONSIBILITY

You must maintain your Greenworks Commercial Mower following the maintenance procedures described in your owner's manual. Such routine maintenance, whether performed by a dealer or by you, is at your expense.

This machine, like any other powered equipment, is potentially dangerous unless properly operated. Any operator must be cautious and keep safety in mind at all times. Any operator, prior to using the Greenworks Commercial Mower, should thoroughly familiarize himself with the owner's manual regarding operation and safety of the machine, as well as all safety warnings on the machine itself.

WARRANTY REGISTRATION

1. Owners must register the unit by filling out the Warranty Registration Form, which is provided in the owner's manual. It **MUST** be completed and signed by the authorized dealer and original purchaser.
2. For validation, the completed Warranty Registration Form **MUST** be forwarded to Greenworks Commercial, within 10 days following date of purchase.
3. The date of purchase constitutes delivery.

Greenworks Commercial Mower Warranty Registration & Manual(s) Received

Name: _____

Address: _____

City: _____ State: _____ Zip Code: _____

Country: _____ Phone Number: _____

Serial Number: _____ Model: _____

Attachments: _____

Purchase Date: _____ Purchased From: _____

GREENWORKS

COMMERCIAL

**Greenworks Tools
PO Box 1238
Mooresville, NC 28115**

TOLL-FREE HELPLINE: 1-855-470-4267

