

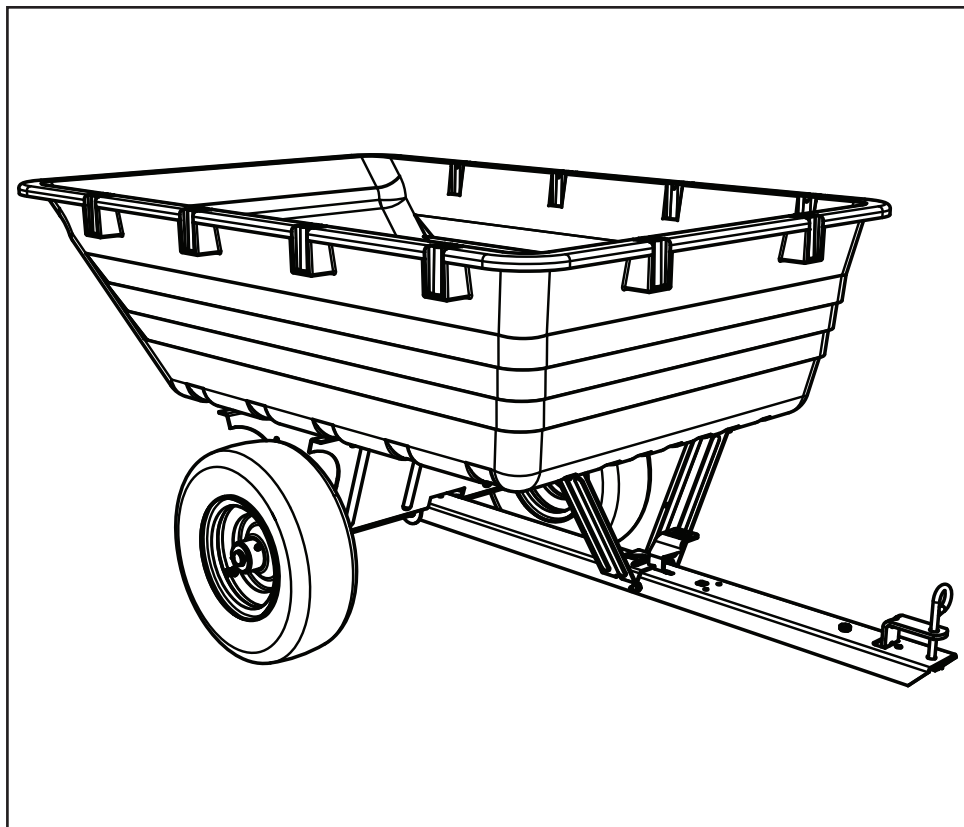

OWNER'S MANUAL

**MODEL NO.
45-05191**

CAUTION:
Read Rules for
Safe Operation
and Instructions
Carefully



UTILITY 17 POLY CART

- Safety
- Assembly
- Operation
- Maintenance
- Repair Parts

SpeedPart *the fastest way to purchase parts* www.speedepart.com

SAFETY

Remember, any power equipment can cause injury if operated improperly or if the user does not understand how to operate the equipment. Exercise caution at all times when using power equipment.



LOOK FOR THIS SYMBOL TO POINT OUT IMPORTANT SAFETY PRECAUTIONS. IT MEANS – ATTENTION! BECOME ALERT! YOUR SAFETY IS INVOLVED.



CAUTION: VEHICLE BRAKING AND STABILITY MAY BE AFFECTED WITH THE ADDITION OF AN ACCESSORY OR AN ATTACHMENT. BE AWARE OF CHANGING CONDITIONS ON SLOPES.

Exercise caution at all times when using power equipment.

1. Read this owners manual before attempting to assemble or operate the cart.
2. Read the vehicle owners manual and know how to operate your tractor, before using the cart attachment.
3. Do not at any time carry passengers in this cart. It has not been designed to carry passengers.
4. Never allow children to operate the tractor or the cart attachment.
5. Do not allow adults to operate the tractor or cart attachment without proper instructions.
6. Always begin with the transmission in first (low) and gradually increase speed as conditions permit.
7. Tow the cart at reduced speed over rough terrain and hillsides or near creeks and ditches to prevent tipping over and loss of control. Do not drive too close to a creek or ditch.
8. Vehicle braking and stability may be affected with the attachment of this cart. Do not fill cart to maximum weight capacity without checking the capability of the towing vehicle to safely pull and stop with the cart attached.
9. Before operating vehicle on any grade (hill) refer to the safety rules in the vehicle owner's manual concerning safe operation on slopes. Refer also to the slope guide on page 9 of this manual. **Stay off steep slopes!**
10. Do not tow this cart on highways or on public thoroughfares.
11. Maximum towing speed is 10 m.p.h.
12. Follow maintenance and lubrication instructions as outlined in this manual.

FULL SIZE HARDWARE CHART

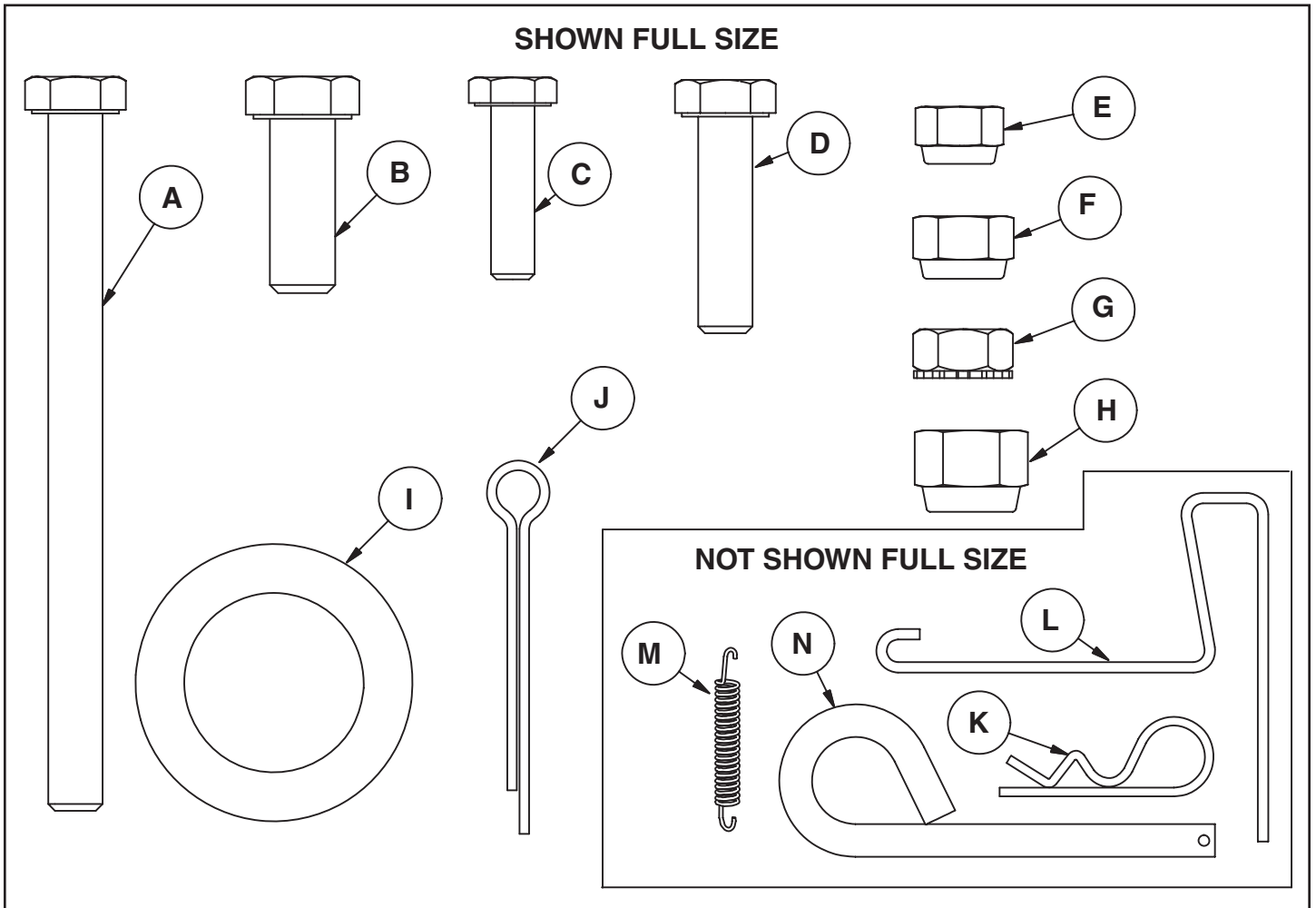

REF	QTY.	DESCRIPTION	REF	QTY.	DESCRIPTION
A	1	Hex Bolt, 5/16" x 4"	H	1	Nylock Nut, 3/8"
B	1	Hex Bolt, 3/8" x 1"	I	4	Flat Washer, 1"
C	4	Hex Bolt, 1/4" x 1"	J	2	Cotter Pin, 9/64" x 1-1/2"
D	8	Hex Bolt, 5/16" x 1-1/4"	K	1	Hair Cotter Pin, 1/8"
E	4	Nylock Nut, 1/4"	L	1	Spring Puller Tool
F	9	Nylock Nut, 5/16"	M	1	Extension Spring
G	2	SEMS Nut, 5/16"	N	1	Hitch Pin

CARTON CONTENTS

- | | | |
|----------------------|------------------------|---------------------|
| 1. Poly Tray | 4. Latch Stand Bracket | 7. Foot Pedal Latch |
| 2. Wheel Support | 5. Draw Bar Tongue | 8. Hitch Bracket |
| 3. Latch Stand Plate | 6. Wheels (2) | 9. Axle |

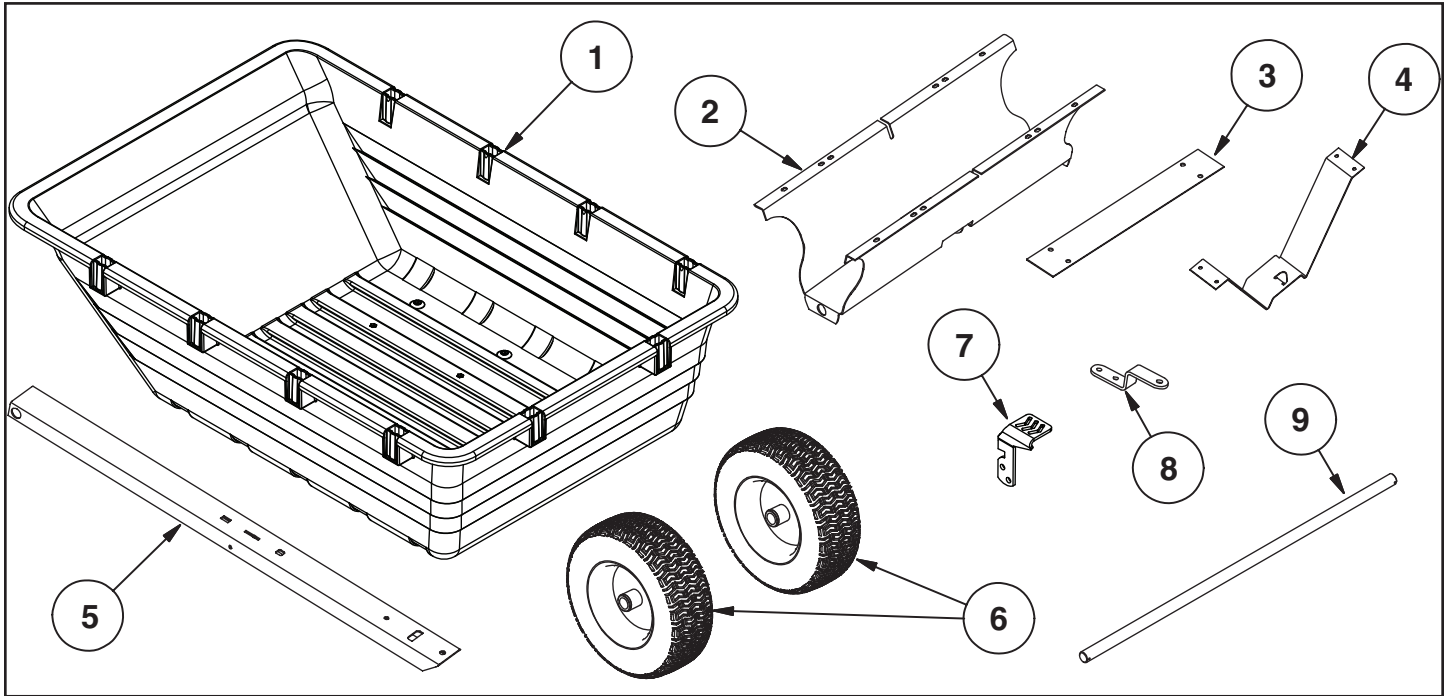

ASSEMBLY

TOOLS REQUIRED FOR ASSEMBLY

- (1) Pliers
- (2) 7/16" Wrenches
- (2) 1/2" Wrench
- (2) 9/16" Wrenches

STEP 1: (SEE FIGURE 1)

- Verify that all parts and all fasteners on pages 3 and 4 are included in the carton and parts bag. Refer to page 3 to identify fasteners used in the following instructions.
- Place the foot pedal latch (7) through the slot in the tongue (5). Assemble the hex bolt (A) through the tongue, the lever, and two (SEMS) hex nuts (G) placed on each side of the lever. Assemble the nylock nut (F) onto the end of the hex bolt (A) and tighten so that the hex bolt (A) can still rotate freely. Tighten the two (SEMS) hex nuts (G) against each side of the foot pedal latch (7) so that it is centered in the slot.

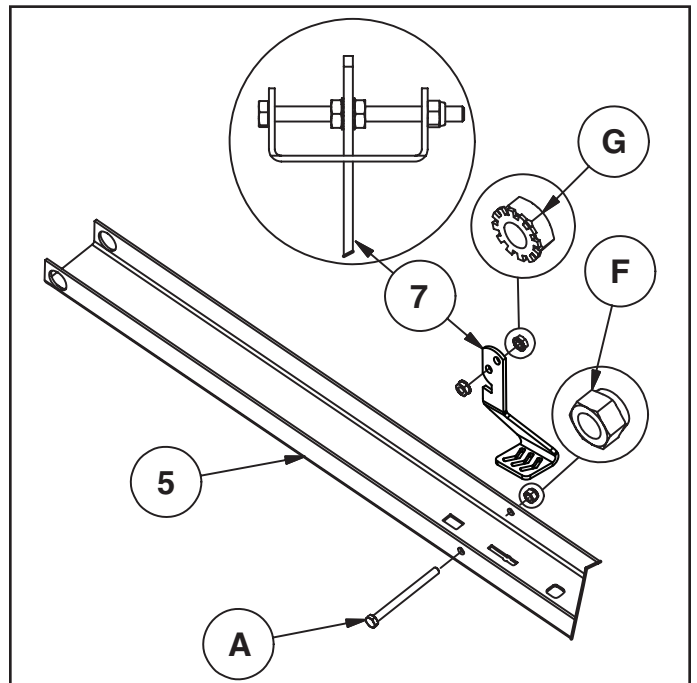

FIGURE 1

STEP 2: (SEE FIGURE 2)

- Hook the short end of the spring (M) into the hole in the foot pedal latch. Use the spring puller tool (L) to hook the long end of the spring into the square hole in the tongue. The spring puller tool can be stored when finished.

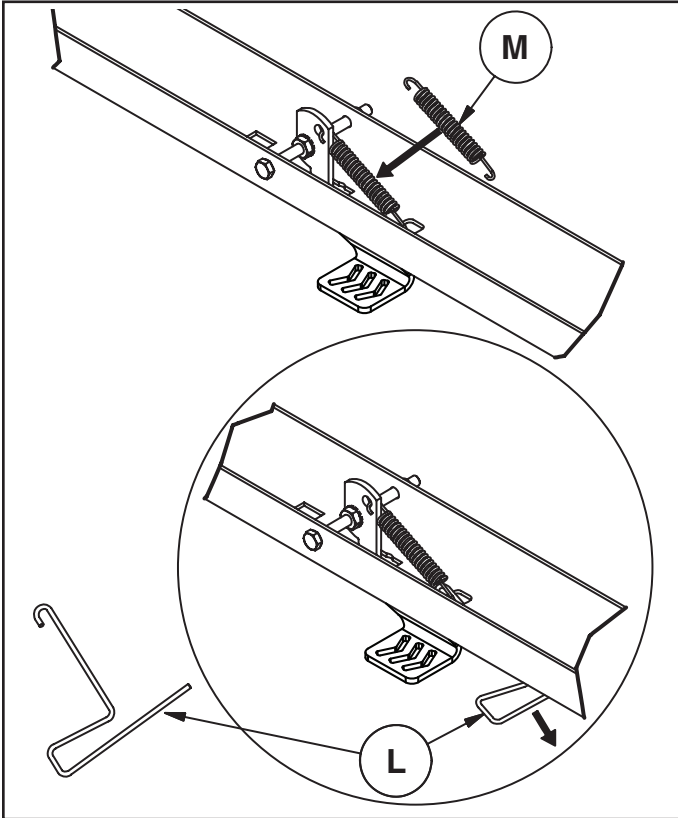

FIGURE 2

STEP 3: (SEE FIGURE 3)

- Assemble the end of the hitch bracket (8) down through the slot at the front of the tongue. Fasten it to the tongue using the hex bolt (B) and hex nut (H). **Tighten.**
- Assemble the hitch pin (N) and hair cotter pin (O) to the tongue and hitch bracket.

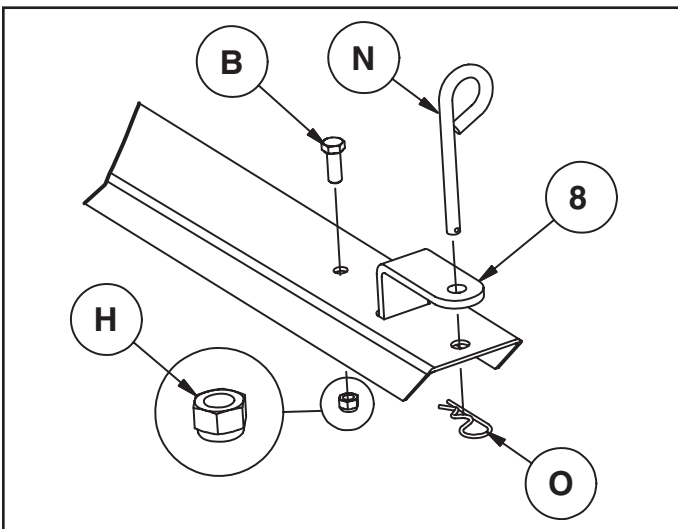

FIGURE 3

STEP 4: (SEE FIGURE 4)

- Lay the tongue (open side facing up) onto the wheel support (2). Assemble the axle (9) through the wheel support and the tongue.

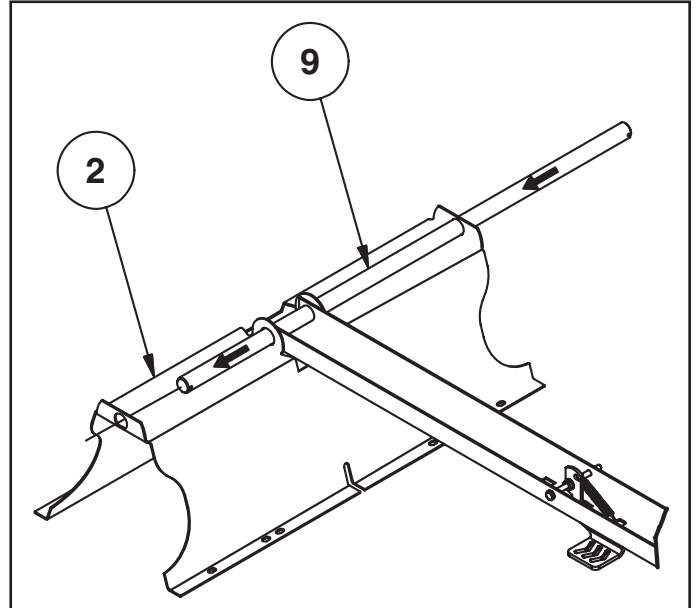

FIGURE 4

STEP 5: (SEE FIGURE 5)

- Assemble a washer (I), a wheel (6) with the valve stem facing out, and another washer (I) onto the axle. Assemble a cotter pin (J) to the axle. Repeat for other wheel.
- Pump wheel bearing type grease into the grease fittings on the wheels until a small amount is forced out the ends of the wheel hubs.

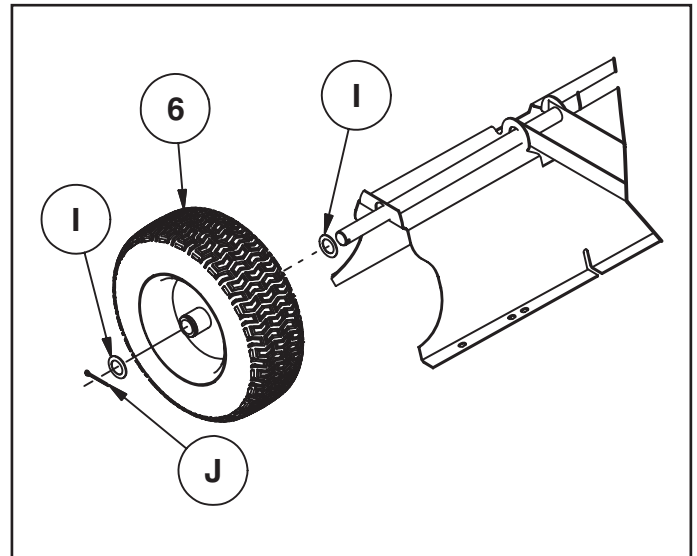

FIGURE 5

STEP 6: (SEE FIGURE 6)

- Assemble the latch stand plate (3) and the latch stand bracket (4) at the front of the tray using four hex bolts (C), and hex nuts (E). The aligning tab on the bottom of the latch stand bracket must be towards the rear of the cart. **Tighten.**

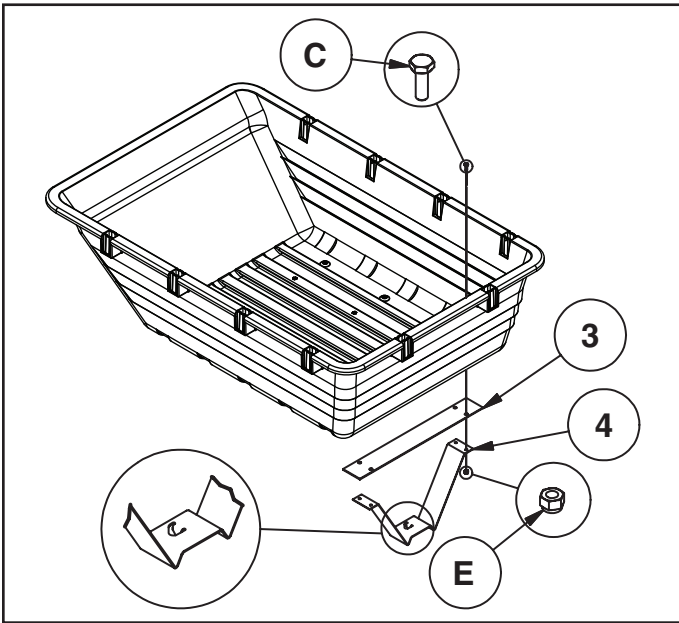

FIGURE 6

STEP 7: (SEE FIGURE 7)

- Place the tray onto the wheel support and position it so that the latch stand bracket locks into the foot pedal latch. Fasten the tray to the wheel support using eight hex bolts (D) and hex nuts (F). **Tighten.**

HINT: Using tape to hold the hex bolts in place may ease assembly.

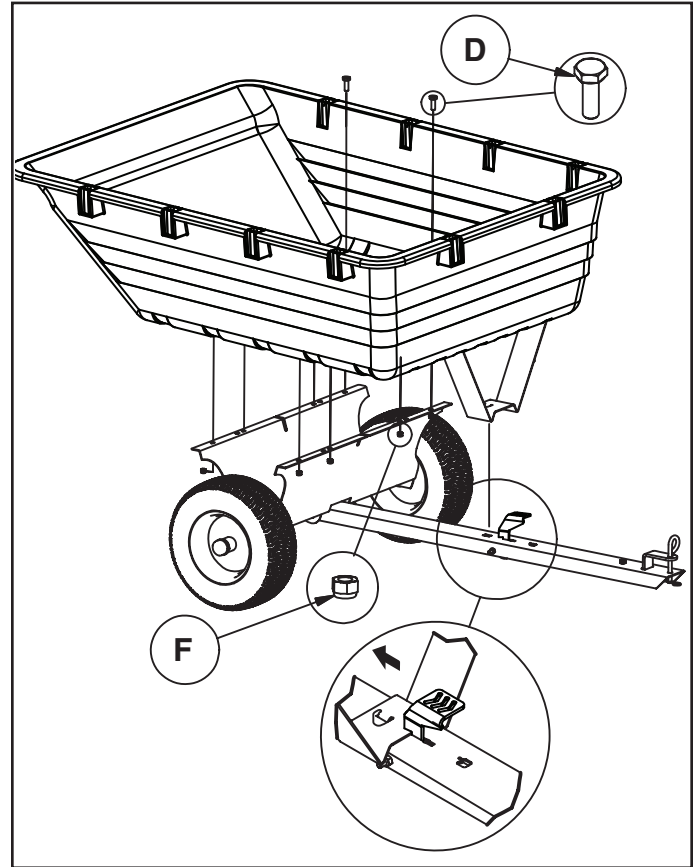

FIGURE 7

NOTES

OPERATION



CAUTION: VEHICLE BRAKING AND STABILITY MAY BE AFFECTED WITH THE ADDITION OF AN ACCESSORY OR AN ATTACHMENT. BE AWARE OF CHANGING CONDITIONS ON SLOPES.

1. Refer to the vehicle owners manual for instructions on safe operation on slopes.
2. Use the slope guide provided on page 9 of this manual to determine whether slope angle is too steep for safe operation.
3. For best handling and traction, distribute the weight of the load evenly in the cart.
4. Always test to make sure your tractor has adequate towing and braking capabilities whenever hauling a substantial amount of weight in your cart. Use extra caution when operating on slopes.

NOTE

DO NOT EXCEED WEIGHT CAPACITY OF CART

(See the specifications on this page.)

One cubic foot of dirt weighs approximately 80 lbs.

5. To dump material from the cart, release the spring latch on the tongue by stepping on the foot pedal latch. The cart bed will then tilt backwards to empty its contents. After emptying, pull the front of the bed down toward the cart tongue until the latch snaps into place.
6. The maximum towing speed for this cart is 10 m.p.h.



CAUTION: TO AVOID POSSIBLE INJURY, BEFORE RELEASING THE LATCH BE SURE THAT NO ONE IS NEAR THE CART.

MAINTENANCE

1. At the beginning of each season, using a light machine oil, lubricate the latch, the latch pivot bolt, and the area of the axle where the draw bar tongue pivots.
2. Grease or oil the wheel bearings periodically. Use automotive wheel bearing type grease or 20 weight oil.
3. Check periodically for loose bolts.
4. Keep tires filled to the recommended tire pressure printed on the tire.

CART SPECIFICATIONS

Tires: 15" x 6" Pneumatic
Axle: 1" Dia. Steel
Capacity: Up to 800 Lbs. Max.
Approx. Sh. Wt. 106 Lbs.

SLOPE GUIDE

(Keep this sheet in a safe place for future reference.)

Use this guide to determine if a slope is safe for the operation of your tractor and cart. Refer also to the instructions in your vehicle owners manual.

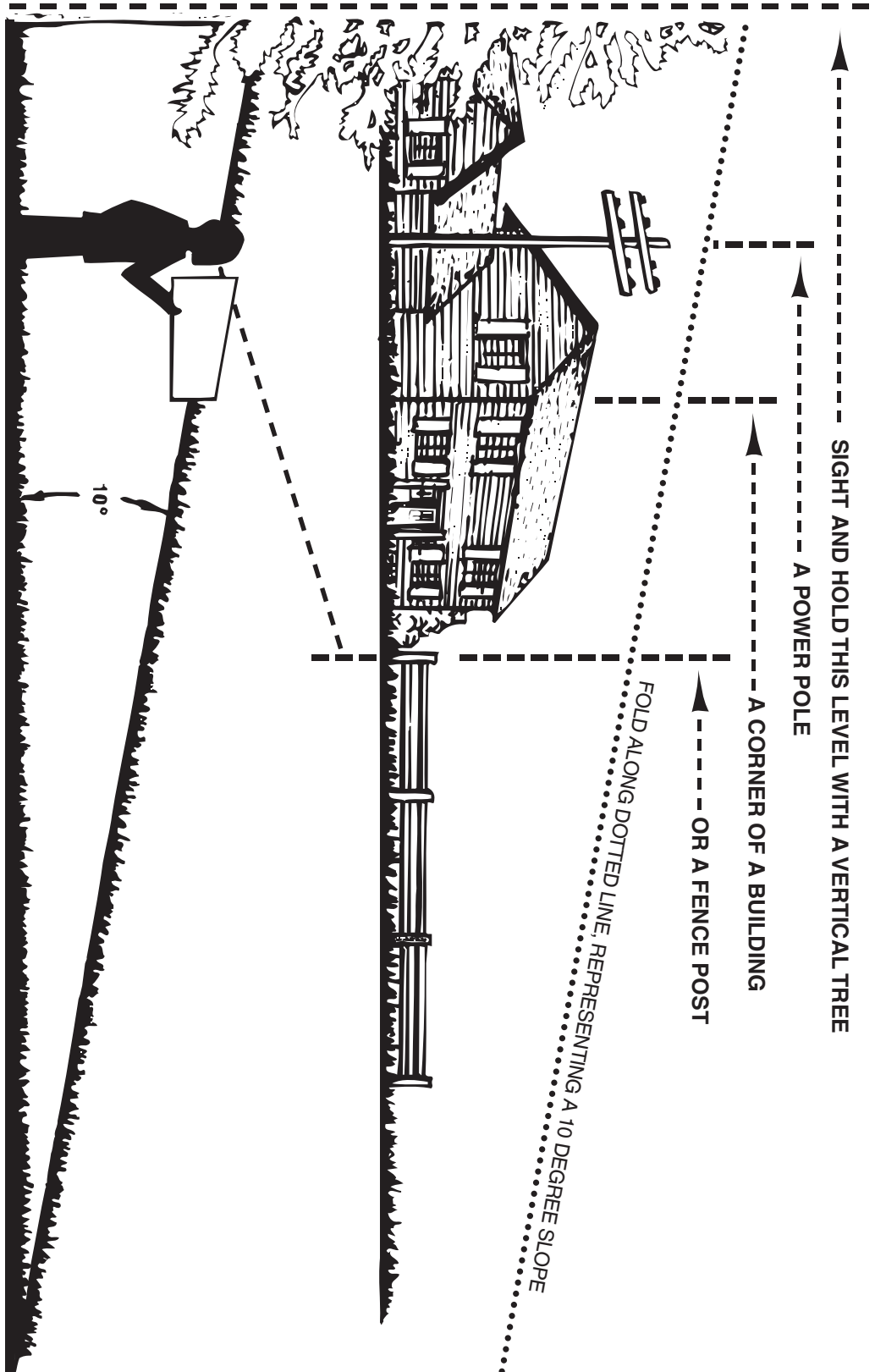

CAUTION: DO NOT OPERATE YOUR TRACTOR AND CART ON A SLOPE IN EXCESS OF 10 DEGREES. BE SURE OF YOUR TRACTOR'S TOWING AND BRAKING CAPABILITIES BEFORE OPERATING ON A SLOPE. AVOID ANY SUDDEN TURNS OR MANEUVERS WHILE ON A SLOPE.

REPAIR PARTS ILLUSTRATION

MODEL NUMBER 45-05191

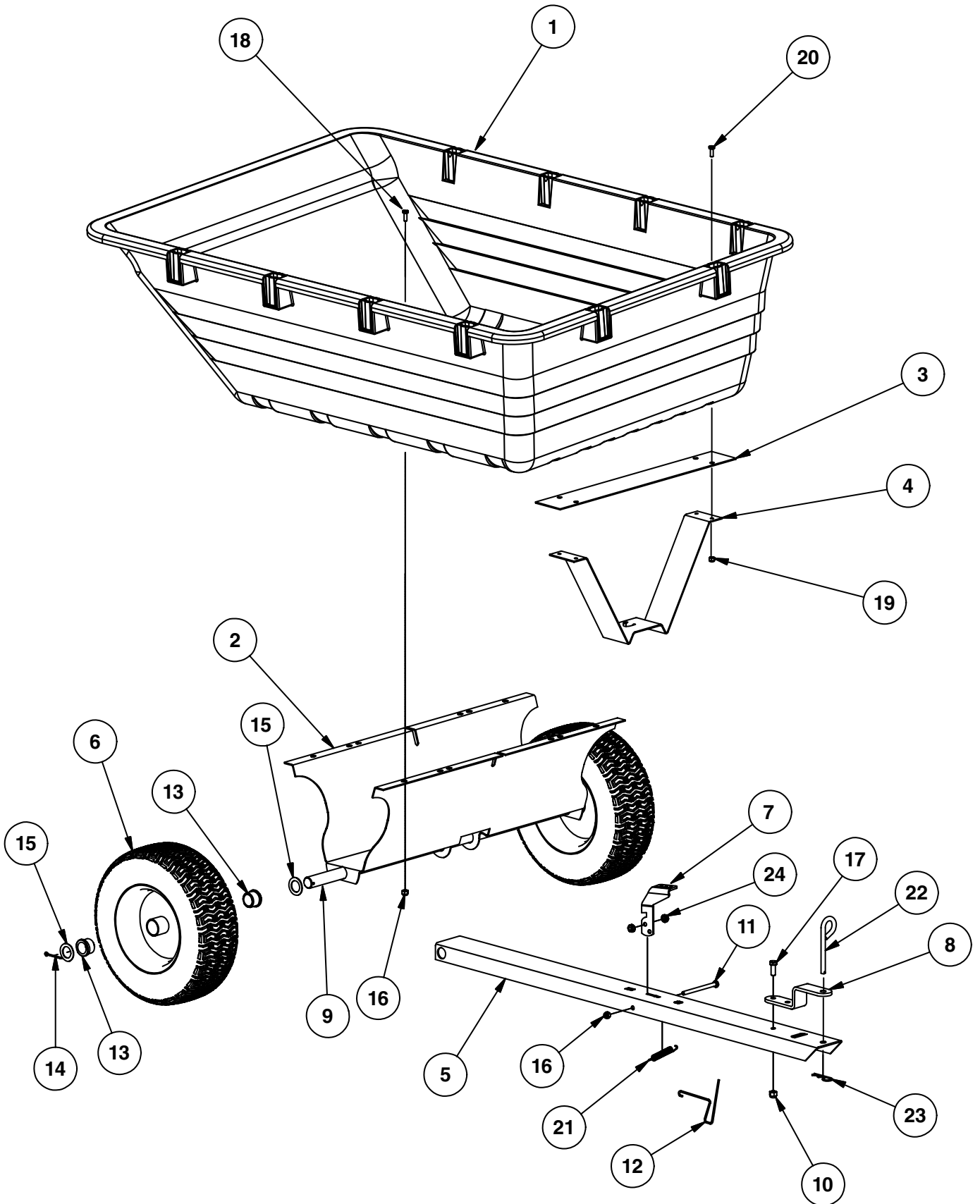

REPAIR PARTS LIST

MODEL NUMBER 45-05191

REF.	PART NO.	QTY.	DESCRIPTION
1	41862	1	Poly Tray
2	25106	1	Wheel Support
3	24386	1	Latch Stand Plate
4	24497	1	Latch Stand Bracket
5	24750	1	Tongue, Draw Bar
6	41483	2	Wheel Assembly
7	28258	1	Foot Pedal Latch
8	23014	1	Hitch Bracket
9	27379	1	Axle, 1"
10	HA21362	1	Hex Nut, 3/8-16 Nylock *
11	47407	1	Hex Bolt, 5/16" x 4"
12	47622	1	Spring Puller Tool
13	41485	4	Wheel Bearing, 1"
14	43501	2	Cotter Pin, 9/64" Dia. x 1-1/2" *
15	43528	4	Washer, 1"
16	47810	9	Hex Nut, 5/16-18 Nylock *
17	43001	1	Hex Bolt, 3/8-16 x 1" *
18	43840	8	Hex Bolt, 5/16-18 x 1-1/4"
19	47189	4	Hex Nut, Nylock 1/4-20
20	43661	4	Hex Bolt, 1/4-20 x 1" *
21	47408	1	Extension Spring
22	23353	1	Hitch Pin
23	43343	1	Hair Cotter Pin, 1/8" *
24	46980	2	Hex Nut, 5/16-18 (SEMS)
	41821	1	Owner's Manual

* Purchase Common Hardware Locally

SpeedPart *the fastest way to purchase parts* www.speedepart.com

REPAIR PARTS
Agri-Fab, Inc.
809 South Hamilton
Sullivan, IL. 61951
217-728-8388
www.agri-fab.com